

SERVICE MANUAL



ISSUE DATE: Jan. 9, 2017



- ▶ Please read the manual carefully and keep it in mind before using this machine.
- ▶ Put this manual within touch of your reference in anytime.

PRECAUTIONS FOR USE

The following safety precautions are given throughout this manual. They must be strictly followed to protect those who install, use or maintain this product as well as to protect players, visitors and property.

For safety reasons.

- The following suggestions should be adhered to:



WARNING

Disregarding could result in serious injury.



CAUTION

Disregarding could result in injury or product damage.

- The following graphic suggestions describe the types of precautions to be followed.



Indicates a care should be taken.



Forbidden.



Indicates a matter which must be performed.

- **Precautions to be followed:**

Certain procedures require a qualified in-shop maintenance person or industry specialist. For such instructions, a qualified person must take care of the jobs.

- Otherwise an electric shock, machine trouble, or a serious accident may result.
- Replacing the machine parts, inspecting and maintaining the machines, and troubleshooting must be assigned only to a qualified in-shop maintenance person or industry specialist. This booklet gives instructions that hazardous jobs in particular must be handled by an industry specialist. Qualified in-shop maintenance person and industry specialist are defined as follows.

Qualified in-shop maintenance person

- A service staff shall have experience in operations of game machines. The staff shall be responsible for assembly, installation, inspection and maintenance of the machine.

Industry specialist

- An industry specialist must be engaged in designing, manufacturing, inspecting and servicing amusement machines. He or she must have an education in electrical, electronic and mechanical engineering, and routinely maintain and repair amusement machines.

PRECAUTIONS FOR USE

WARNING

Be sure to consult an industry specialist when setting up, moving or transporting this product.

- This product should not be set up, moved or transported by any one other than an industry specialist.
- When installing this product, set the 4 leg levelers evenly on the floor and make sure that the product is installed stably in a horizontal position. Unstable installation may result in injury or accident.
- When installing this product, do not apply undue force on movable parts. Otherwise, injury and accident may result, or the product may be damaged.

The machine for indoor usage only does not install outside.



Do not set the game machine up near emergency exits.



Protect the game machine from:

- Rain or moisture.
- Direct sunlight.
- Direct heat from air-conditioning and heating equipment, etc..
- Hazardous flammable substances.
- Otherwise an accident or malfunction may result.



Do not place containers holding chemicals or water on or near the game machine.



Do not place objects near the ventilating holes.



Do not bend the power cord by force or place heavy objects on it.



Never plug or unplug the power cord with wet hands.



Never unplug the game machine by pulling the power cord.



CAUTION

Be sure to use indoor wiring within the specified voltage requirements. For extension cord, use the specified rating or more.

Be sure to use the attached power cord.

Never plug more than one cord at a time into the electrical receptacle.



Do not lay the power cord where people walk through.



Be sure to ground this product.



Do not exert excessive force when moving the machine.



For proper ventilation, keep the game machine 100mm(4") away from the walls.

Do not alter the system related dipswitch settings.

PRECAUTIONS FOR USE

WARNING

If there is any abnormality such as smoke, bad smell or abnormal noise being emitted from the machine, immediately turn OFF the main power switch and unplug the power cord from the receptacle to stop operating it. 

- Using the machine in abnormal conditions could result in fire or accidents.

In case of abnormality

1. Turn OFF the main power switch.
2. Unplug the power cord from the receptacle.
3. Contact your nearest dealer.

Do not leave the power cord plugged in improperly or covered with dust. 

- Doing so could result the power cord periodically.

CAUTION

Do not use this product anywhere other than industrial areas. 

- Using in a residential area or an area next to a residential area could affect signal reception of radios, television sets, telephones, etc..
- Do not give shock the surface of glass products.

- Please do not play this game if
 - When you do drinking;
 - When your physical condition is not normal;
 - When you are in pregnancy;
 - When you have on a pulse controller;
 - When you have recently experienced a cramp or fainting away while watching TV.
- Avoid excessive force/shock while playing/moving the game.
- While do games, pay attention to surrounding.

Do not plug or unplug the power cord with wet hands. 

In handling the power cord, follow the instructions below. 

- | | |
|---|--|
| • Do not damage the power cord. | • Do not modify the power cord. |
| • Do not bend the power cord excessively. | • Do not twist the power cord. |
| • Do not heat the power cord. | • Do not pull the power cord. |
| • Do not bind the power cord. | • Do not stand on the power cord. |
| • Do not sandwich the power cord. | • Do not drive a nail into the power cord. |

If the power cord or power plug becomes damaged, stop using the machine immediately and ask your nearest dealer to replace the parts.

*** Electromagnetic wave may cause unexpected noise from speaker.**

PRECAUTIONS FOR USE

⚠ WARNING

Be sure to turn OFF the main power switch and unplug the power cord from the receptacle before inspecting or cleaning the machine.



When replacing parts, be sure to use parts of the correct specifications. Never use parts other than the specified ones.



Opening inside the machine shall be done by machine specialist only as high electric current is being sent inside. For game machine with monitor, a care should be taken while opening its back door. If not, a damage to the inside parts or the monitor may occur.



If the sub power switch of the service panel is turned OFF without turning OFF the main power switch of the power supply unit, some parts in the units remain live. When opening the back door, be sure to turn OFF the main power switch and unplug the power cord from the receptacle.



Strictly refrain from disassembly and repair of parts which are not indicated in this manual, as well as settings and remodeling.



To clean the game machine, wipe it with a soft cloth dampened in a neutral detergent.

- Using thinner or other organic solvent or alcohol may decompose the material.
- Electrical shock or equipment failure could be caused by water entering the inside of the machine.

⚠ CAUTION

Components in the game are sensitive to vibrations and impact. Care should be used when moving and transporting the game machine.



Be sure not to let the machine tip over.

Before moving the machine, be sure to turn OFF the main power switch, unplug the power cord from the receptacle and remove the power cord from the machine.



Before moving take the machine, off the levelers and move it on the casters.

Avoid excessive force while moving the machine.

.....

PRECAUTIONS IN HANDLING

- When setting up, inspecting, maintaining, moving or transporting this product, follow the procedures and instructions set forth in this manual and perform such work safely.
- Do not set up, handle, inspect, maintain, move or transport this product under conditions equivalent to the condition of "WARNING" or "CAUTION" specified in this manual.
- If a new owner is to have this product as a result of transfer, etc., be sure to give this manual to the new owner.

CONTENTS

1. SPECIFICATION AND DIMENSION	P02	6-11. MIDDLE LED PCB ERROR_CENTER (all)	P39
1-1. DIMENSION	P02	6-12. MIDDLE LED PCB ERROR_L,R (all)	P40
1-2. SPECIFICATION	P02	* MIDDLE LED PCB ERROR (part)	P41
1-3. NAME OF PARTS	P03	6-13. BILLBOARD LED PCB ERROR (all)	P42
1-4. STICKER LOCATION	P04	* BILLBOARD LED PCB ERROR (part)	P43
1-5. COMPONENTS	P05	6-14. BOTTOM LED PCB ERROR (all)	P44
2. INSTALLATION	P06	6-15. SIDE L LED ERROR (all)	P45
2-1. INSTALLATION SPACE	P06	6-16. SIDE R LED ERROR (all)	P47
2-2. HOW TO INSTALL	P07	6-17. WOOFER BOX L LED ERROR (all)	P49
3. GAME CHARACTERISTICS	P09	6-18. WOOFER BOX R LED ERROR (all)	P51
4. HOW TO PLAY	P09	* COMMON_LED PCB ERROR (part)	P53
5. SETUP MENU	P10	* IF ALL THE COLOR LEDS ARE NOT LIGHT ON	P54
5-1. SYSTEM INFOMATION	P11	* WHEN THE COLOR LED IS LIT ONLY IN RED, GREEN, BLUE, AND WHITE	P54
5-2. I/O TEST	P12	* WHEN THE COLOR LED IS ONLY LIT IN WHITE, BLUE, OR OFF	P55
5-3. CARD READER CHECK UP	P15	6-19. WHEN THE WHITE LIGHT AND THE BLUE LIGHT COME OUT ONLY OCCASIONALLY (EQ malfunction)	P56
5-4. CAMERA CHECK UP	P16	6-20. SOUND ERROR	P57
5-5. GAME SETTING	P17	7. EXPLODED VIEW	P59
5-6. CREDIT SETTING	P18	7-1. MAIN CABINET PART	P59
5-7. USB DRIVE	P19	7-2. POWER BASE PART	P60
5-8. CARD READER	P20	7-3. COIN DOOR CASE PART	P61
5-9. SOUND SETTING	P21	7-4. SETUP PANEL PART	P62
5-10. BOOKKEEPING	P22	7-5. MONITOR PART	P63
5-11. STATISTICS	P23	7-6. PC BASE PART	P64
5-12. RESTRICTION	P24	7-7. PCB BASE PART	P65
5-13. FACTORY SETTING	P25	7-8. AC INPUT PART	P65
6. TROUBLESHOOTING	P26	7-9. LAN CABLE PART	P65
6-1. MONITOR	P26	7-10. MID SPEAKER SIDE COVER L,R PART	P66
6-2. BUTTON	P27	7-11. SPEAKER DECO PART	P67
6-3. STEP SENSOR	P28	7-12. WOOFER SPEAKER COVER L,R PART	P68
6-4. STEP LED	P29	7-13. LIGHT COLUME L PART	P69
6-5. COIN SELECTOR	P30	7-14. MID SPEAKER FRONT COVER PART	P70
6-6. WHEN INTERNET COMMUNICATION DOES NOT WORK	P32	7-15. BILLBOARD PART	P71
6-7. USB ON/OFF ERROR	P33	7-16. BASE LIGHT DECO PART	P72
6-8. CARD READER ERROR	P35	7-17. [OPTION] POP PART	P73
6-9. WEB CAM ERROR	P37	8. BLOCK DIAGRAM	P74
6-10. BILLBOARD LED ERROR	P38		

1. SPECIFICATION AND DIMENSION

1-1. DIMENSION

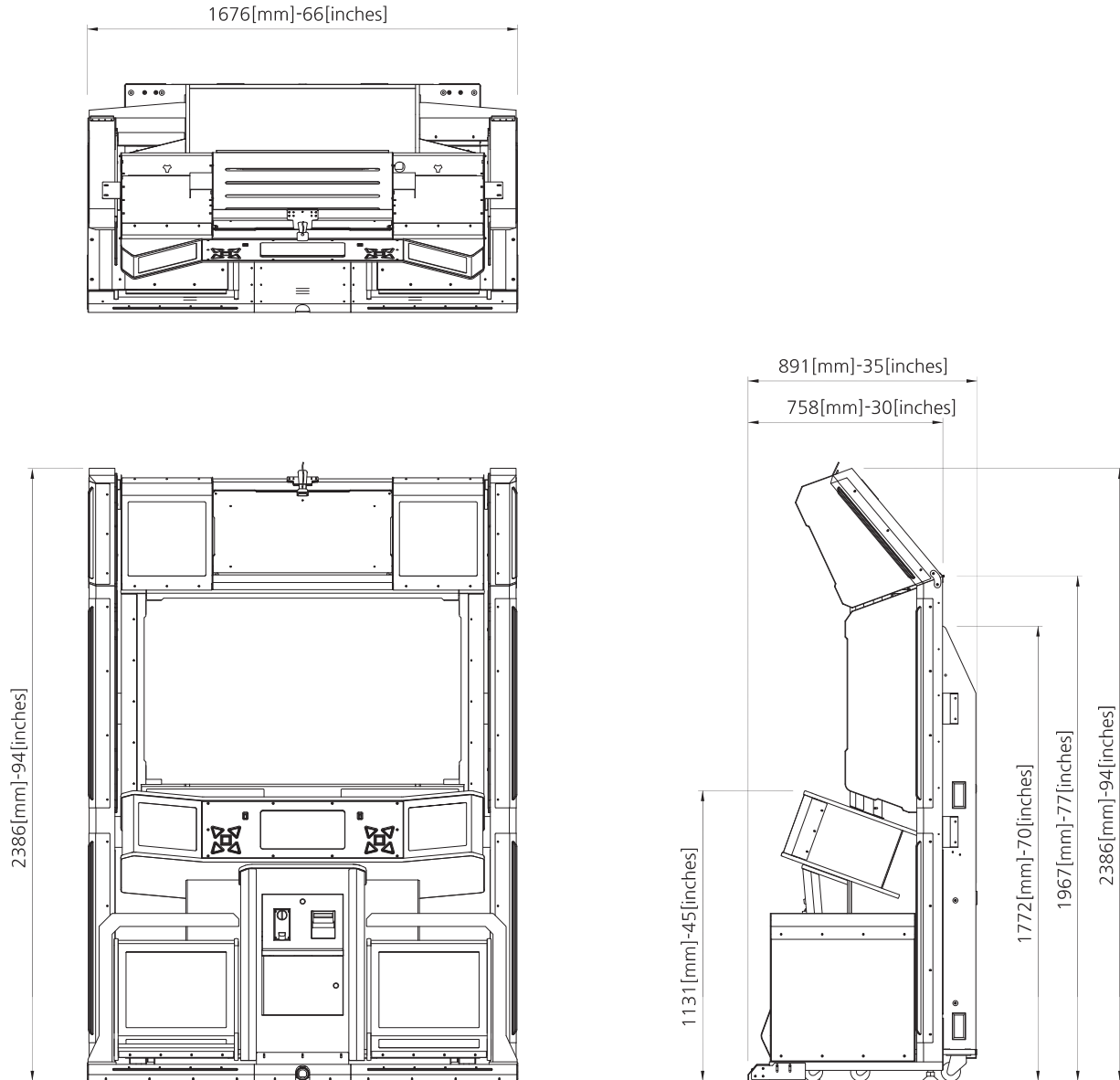

1-2. SPECIFICATION

DIMENSION (W x D x H)	1676 x 891 x 2386 (mm)
PACKING DIMENSION (W x D x H)	- x - x - (mm)
WEIGHT (kg)	- kg [WEIGHT INCLUDING : - kg] PACKAGING]
VOLTAGE	AC 120V, 220V
FREQUENCY RANGE	50~60Hz
CONSUMPTION	650 W

1-3. NAME OF PARTS

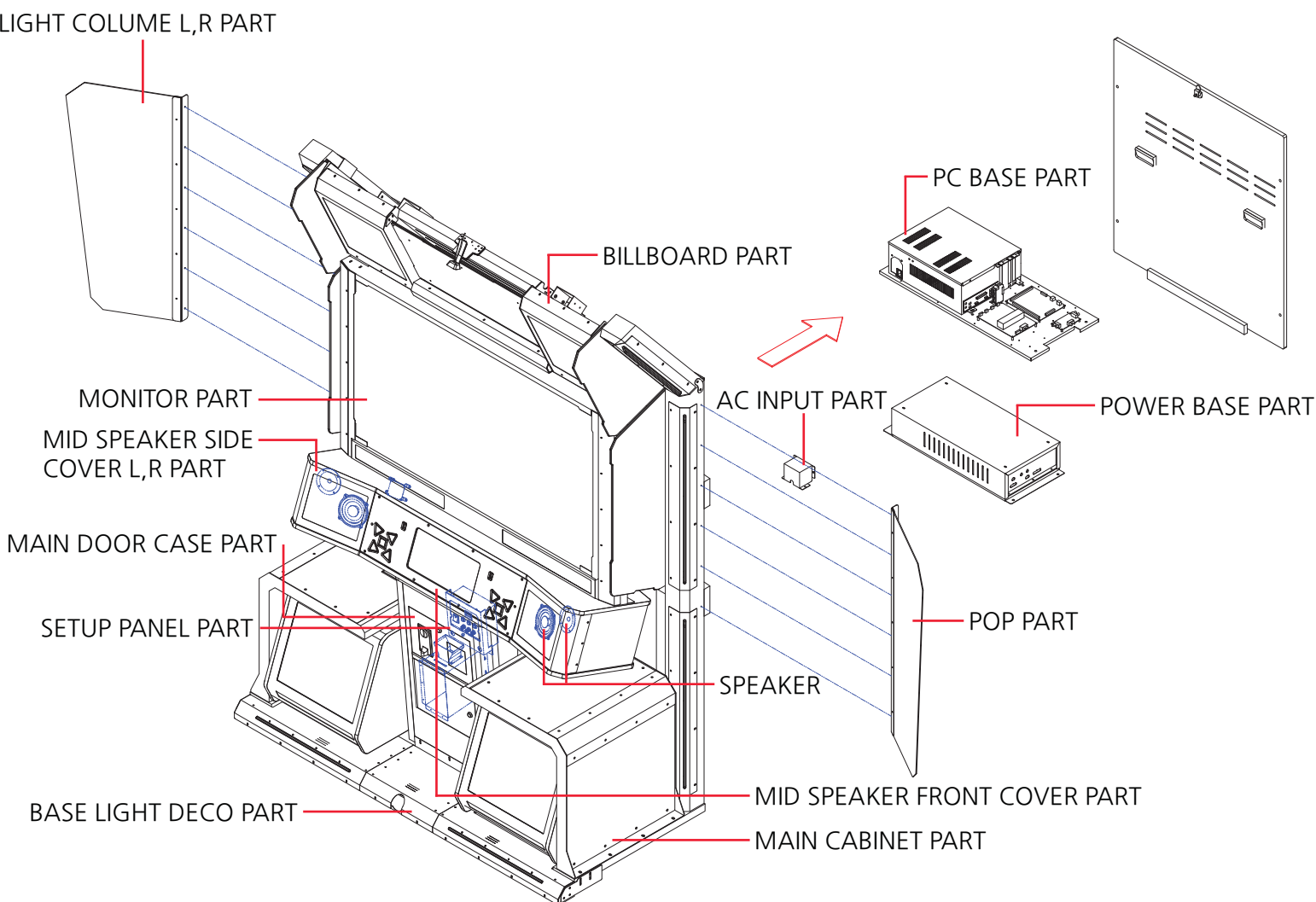

1-4. STICKER LOCATION

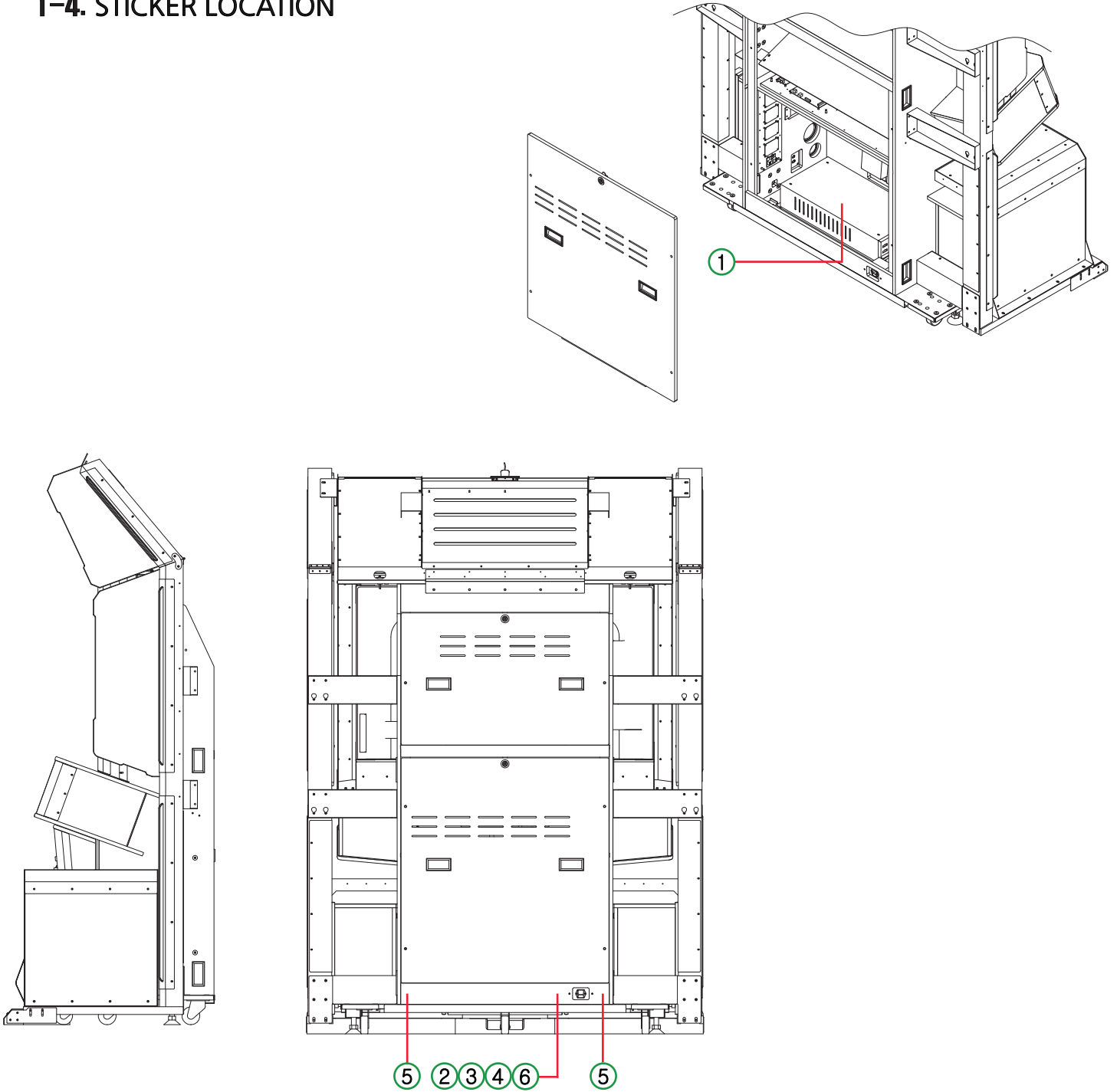

1

⚠ WARNING/ATTENTION

Except service personal, please never open the product as there is a risk of electric shock.

Il y a un risque d'électrocution, n'ouvrez pas le produit excepté le responsable, s'il vous plaît.

2

⚠ CAUTION/PRUDENCE

"For continuous protection against risk of fire, replace only with the same type 10A-250V fuse"

"Pour une protection continue contre les risques d'incendie, remplacer un fusible avec seulement le même type 10A-250V"

3



4

WARNING
ROCKING, SHAKING, OR TIPPING
MAY CAUSE INJURY OR DEATH!
This unit must be fastened securely to the wall, floor or adjacent object in compliance with the installation instructions.

ATTENTION
AGITER, SECOUER OU BASCULER
PEUT CAUSER DES BLESSURES
OU ENTRAINER LA MORT!
Cette unité doit être fixée au mur, au plancher ou à un objet à proximité conformément aux instructions d'installation.

5

NOTICE











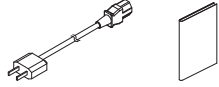

FORK

↓

6

MODEL NAME	-
PRODUCT S/N	-
MAIN BOX S/N	-
LOD S/N	-
CERTIFICATE	-
MADE IN KOREA	
Koyung-wi, Kyounggi-do, Korea. Phone: 82-31-909-2100	

1-5. COMPONENTS

NO.	PART NAME	SPEC.	QTY
1	AC POWER CORD, MANUAL	- 	Each 1
2	KEY	6001, 7001 	2
3	WIRING	- 	1
4	CONNECTOR BRACKET-[STEP]	- 	1
5	JOINT BRACKET	- 	2
6	STEP STICKER	- 	1
7	WRENCH	4mm, 6mm, 8mm 	Each 1
8	BOLT	M4x8L 	15
9	BOLT	M4x16L 	8
10	BOLT	M6x16L 	14
11	BOLT	M6x20L 	6
12	BOLT	M8x15L 	18
13	BOLT	M10x16L 	20
14	REMOTE CONTROL	- 	1

2. INSTALLATION

2-1. INSTALLATION SPACE

- Need to have installation place.
Maintenance Zone & Play zone should have at least 2500mm x 3500mm each.

IMPORTANT

- Once you set up the machine with required game-play area, when installing this product, set the 4 leg levelers evenly on the floor and make sure that the product is installed stably in a horizontal position. Otherwise the set winning percentage can be twisted.

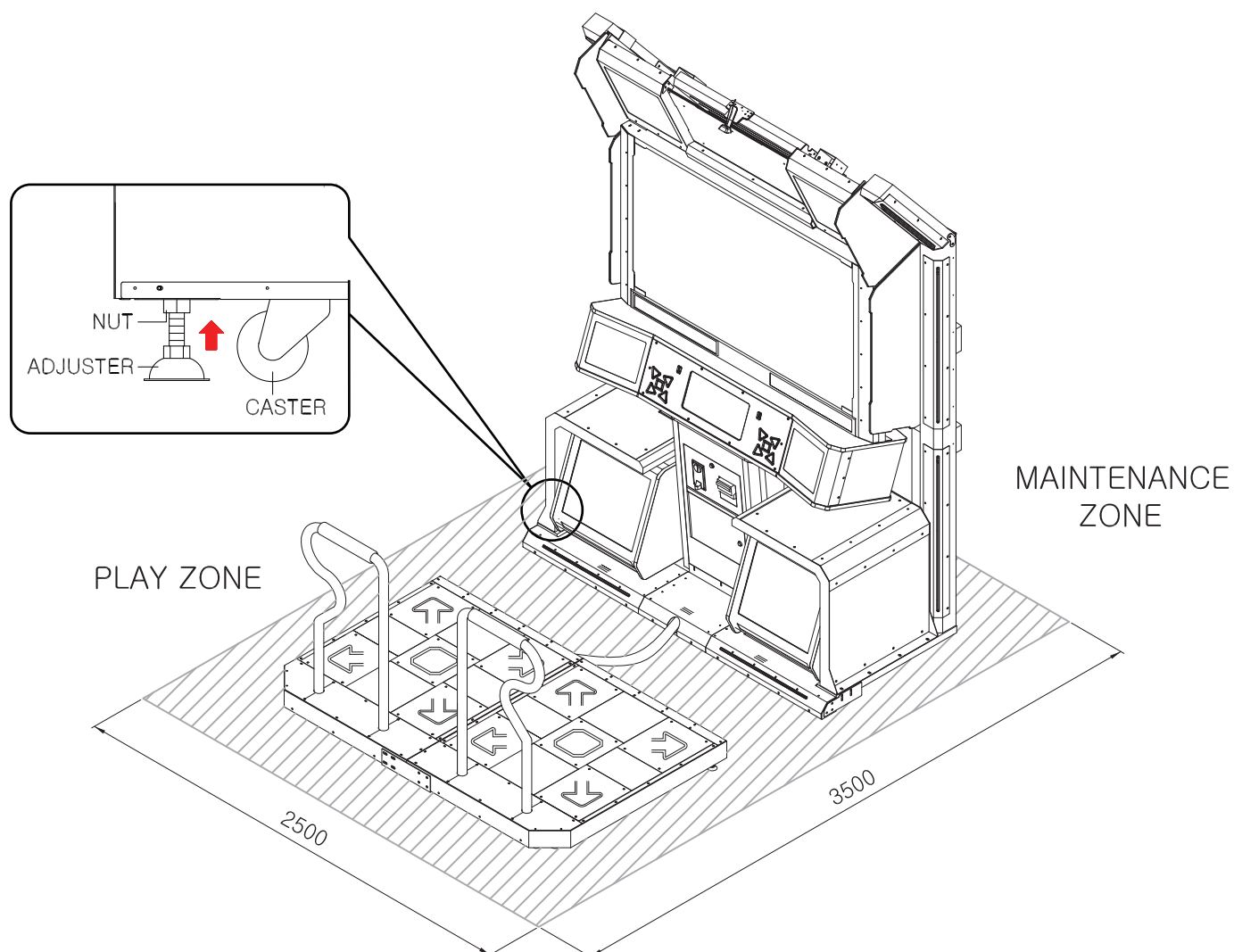

2-2. HOW TO INSTALL - BILLBOARD & BASE LIGHT DECO

1

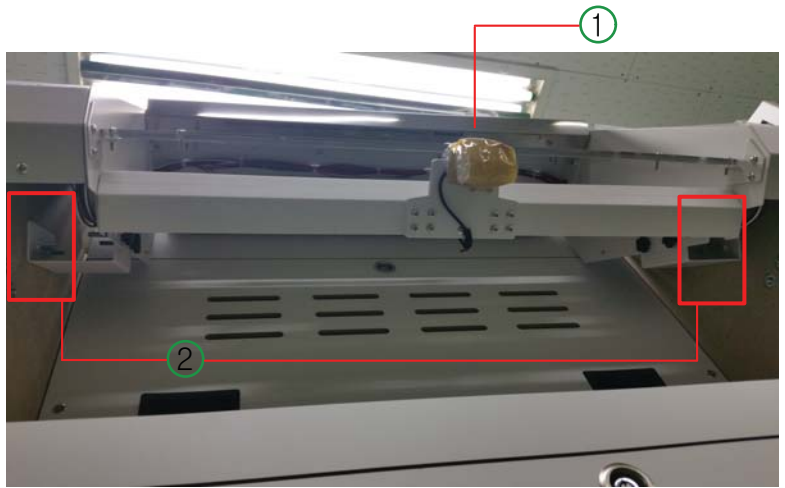
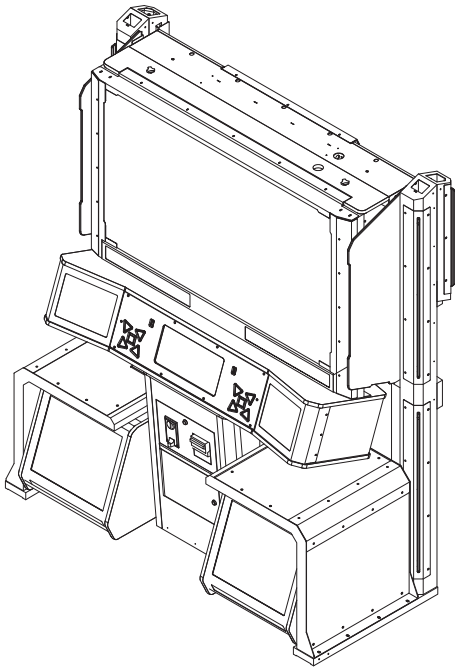

- ① The billboard is fixed to the backside by hinge when it released as following picture.
Release ② hand Bolts(4 pcs) following display parts in the picture, then install the billboard.

2

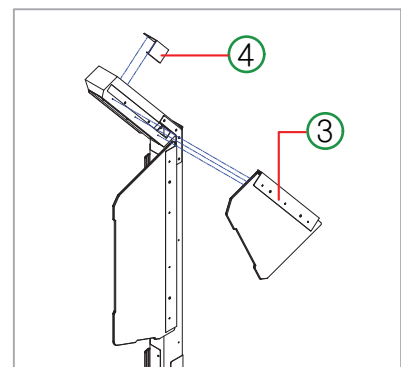
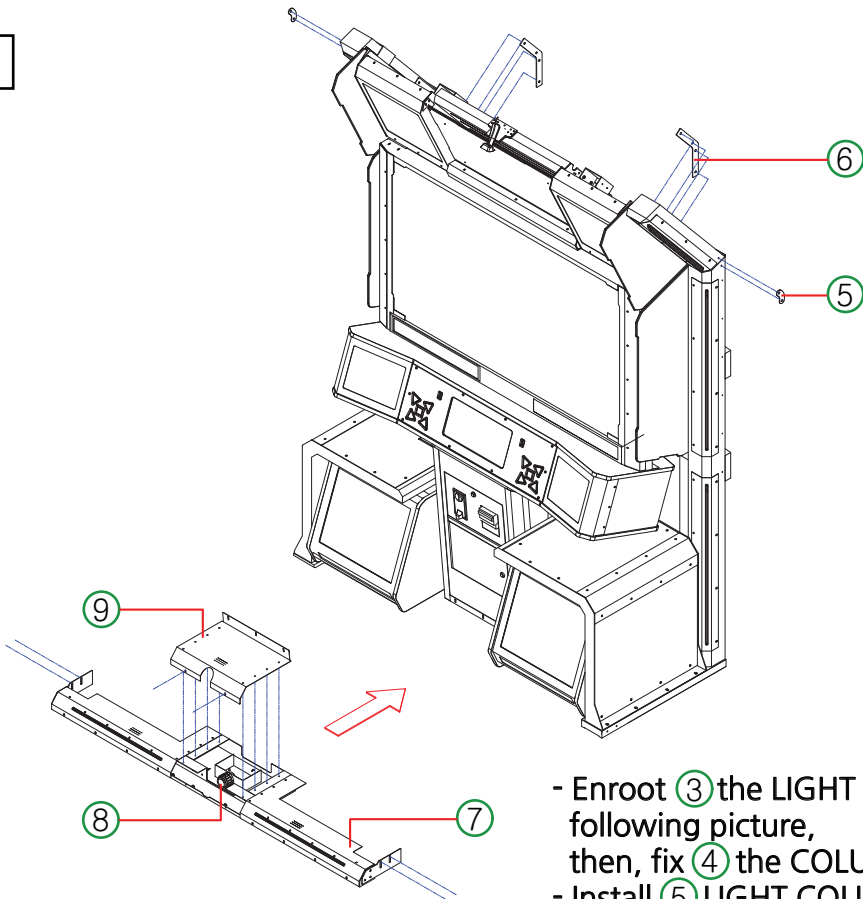

- When assembling ③, connect a connector.

- Enroot ③ the LIGHT COLUME L and R[M4 Bolt, 3pcs each] as following picture, then, fix ④ the COLUME REAR FIX BKT.
- Install ⑤ LIGHT COLUMN FOLDING BKT and ⑥ LIGHT COLUMN FOLDING LARGE BKT.[M4 bolt, 6pcs each]
- then, assemble ⑦ BASE LIGHT DECO ASS'Y to CABINET. [M6 bolt, 4pcs]
- after connect the foot connector used by ⑧ HARNESS COVER
- Enroot the ⑨ BASE LIGHT DECO CENTER COVER BKT. [M4 bolt, 13pcs each]

3

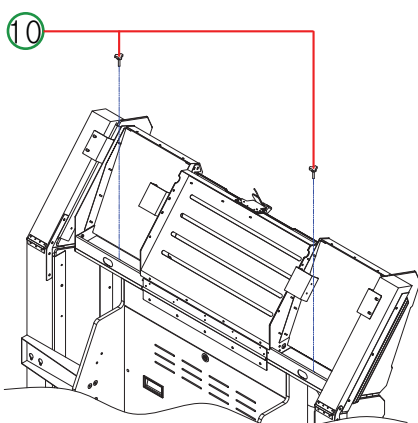

- At the last step, Complete the billboard assembly with ⑩ [M6 bolt, 2pcs] as following picture.

- STEP

4

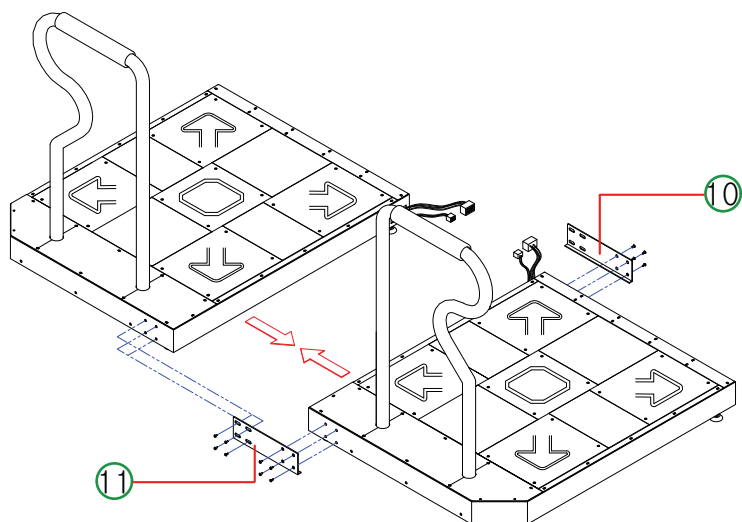

- As shown in Figure A left and right feet of the 1P and 2P is connected to the connector. M8 bolts to 10 11 JOINT BRACKET (16 points) is fixed by.

5

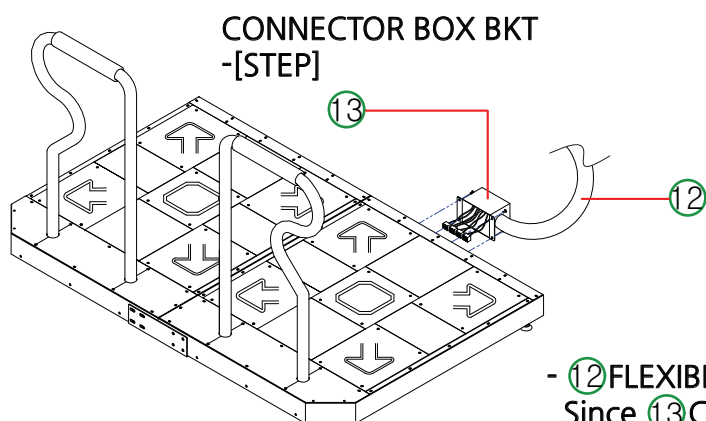

- 12 FLEXIBLE TUBE is connected to the connector body and feet. Since, 13 CONNECTOR BOX BRACKET-[STEP] connection. Bolt M6 (4 points)

6

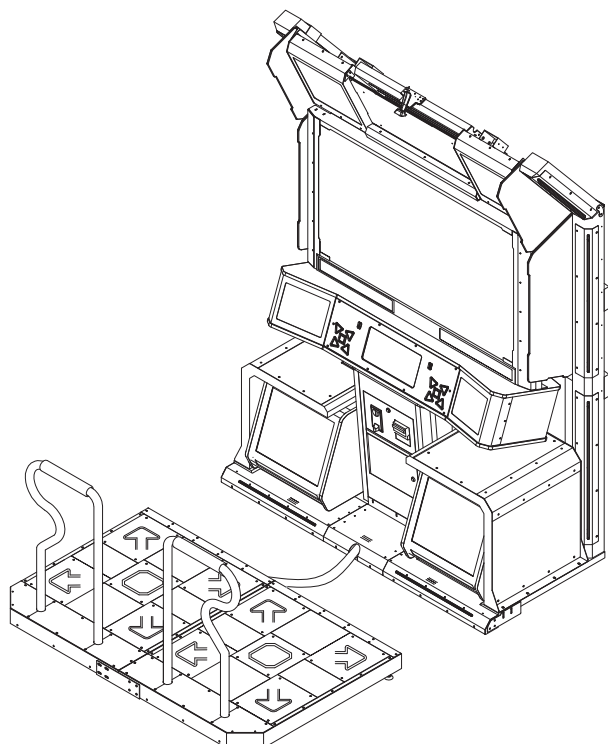

- Finish it as like 5 picture.

3. GAME CHARACTERISTICS

- 3-1. New brilliant light show, upgrades any location!
- 3-2. Unleash the Wall of Sound with 4 speakers and 2 subwoofers.
- 3-3. HD Graphics Pop on a Giant 55" Screen.
- 3-4. Consistent Revenue with AM.PASS card(PIU login card)
- 3-5. Collaboration

- 1. We put a lot of music in various genre by collaboration with international popular
- 2. This is the most biggest scale of PIU history by adopting songs of popular K-POP line ups and famous composers.

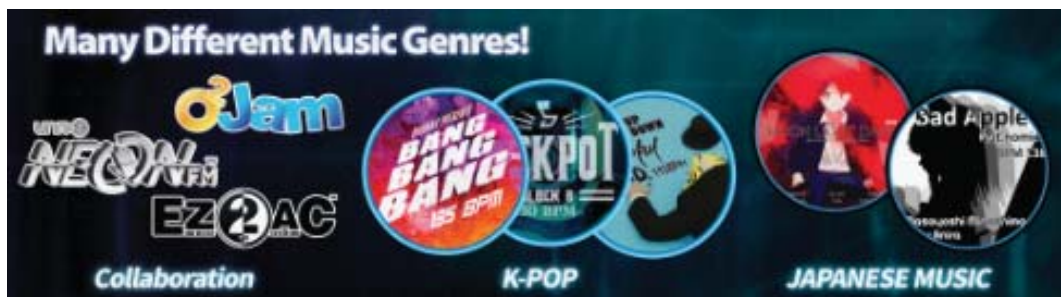

3-6. Regular update

- 1. By the strong point of network system, regular new songs & contents update can be appealed to casual and mania players.
- 2. By grand update, which is first time concept we try, the name will be changed from PRIME 2 2017 to PRIME 2 2018 as well as game title logo. Moreover, enhanced graphics and big amount of new songs & contents update will make the people to feel the machine as a new product. That will lead users to the game center again.

4. HOW TO PLAY

② Continuous Play for Core Players = Higher Income!

AM.PASS + PIU mobile web

Continuous Play with AM.pass card!
AM.pass card can be used immediately after purchase

Song & Step unlock

EXP +
Extra EXP

Extra Points

- 1. You can only use AM.NET service while the machine is online. songs & contents update can be appealed to casual and mania players..
- 2. You can buy AM.PASS card from the game center which is installed card reader. You can use AM.NET service right away. You can use AM.NET service by AM.PASS card providing by Andamiro.
- 3. When you first use the service, you will use temporary ID. If you register AM.PASS card on www.piugame.com, you can change ID and use various services

5. SETUP MENU

Setup the machine proper for your own game center.

Test the hardware and set options before using game.

* Press the "Test" button located in the service box at any time.
The Service Options menu will appear.

* Moving menu items : TEST Button, CLEAR Button
Selection of menu items : SERVICE Button



- SYSTEM INFO : CHECK SPEC INFO AND INTERNET CONNECTION
- IO TEST : CHECK THE FUNCTION OF IN/OUT DEVICE
- GAME STEUP : SET UP FOR GAME
- CREDIT SETUP : SET UP FOR CREDIT
- USB DRIVE : SET UP FOR USB DRIVE
- CARD READER : SET THE CONDITIONS OF READER
- SOUND SETUP : SET UP FOR GAME SOUND
- INCOME DISPLAY : DISPLAY THE SALES LEDGER LIKE INSERTED COIN
- FAVOURITE : CHECK THE PLAYER'S FAVORITE
- LIMIT SONG : SET UP FOR SONG'S SOURCE
- FACTORY SETTING : INITIALIZING WITH FACTORY SETTING VALUE

5-1. SYSTEM INFORMATION

- CHECK SPEC INFO, INTERNET CONNECTION INFO AND STATUS OF MACHINE

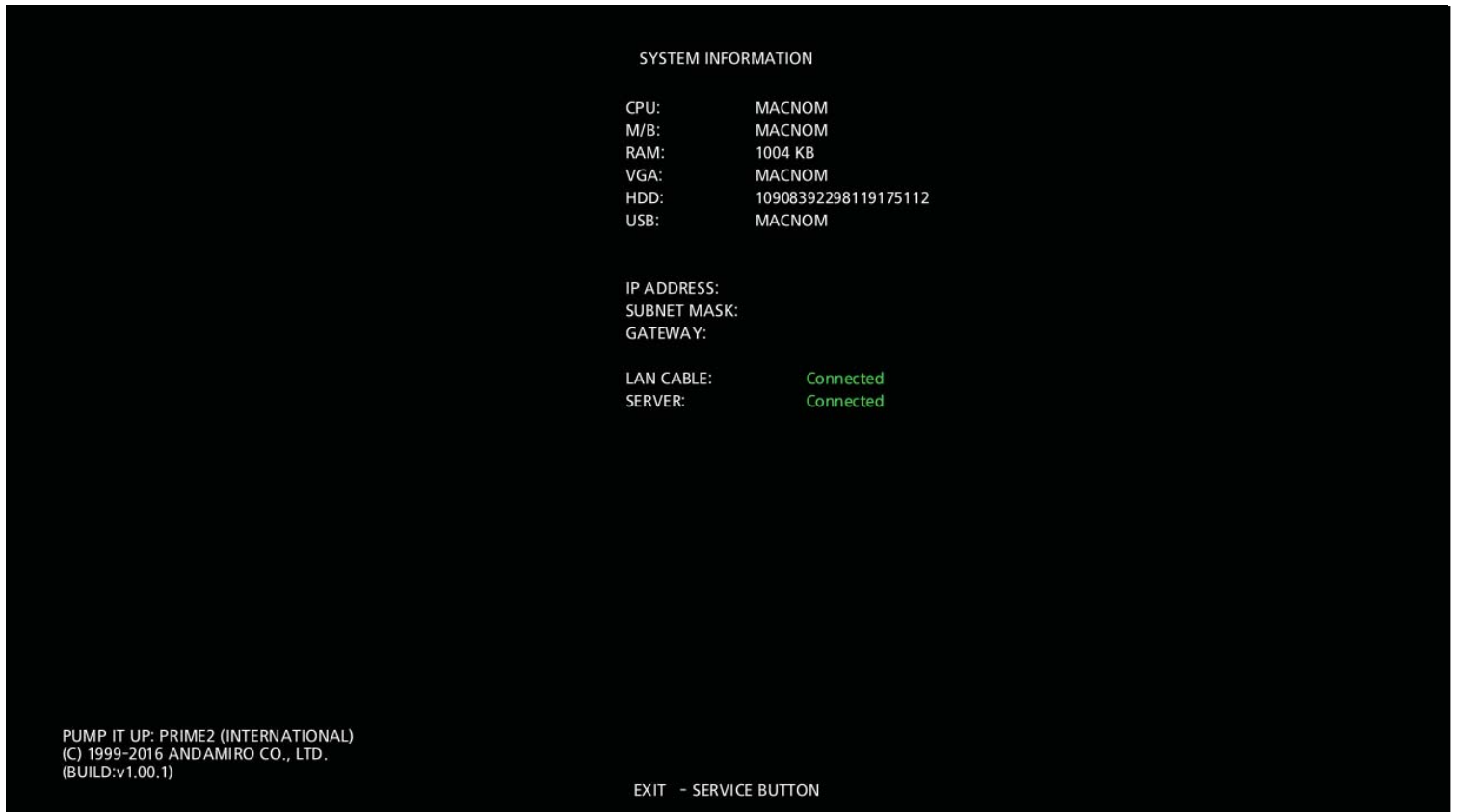

- CPU : CHECK CPU INFO
- M/B : CHECK MAINBOARD INFO
- RAM : CHECK RAM INFO
- VGA : CHECK GRAPHIC CARD INFO
- HDD : CHECK HARD DISC INFO
- USB : CHECK USB INFO
- IP ADDRESS : CHECK IP ADDRESS INFO
- SUBNET MASK : CHECK SUBNET MASK INFO
- GATE WAY : CHECK INTERNET CONNECTION STATUS
- LAN CABLE : CHECK INTERNET CONNECTION STATUS
- SERVER : CHECK THE CONNECTION WITH SERVER

5-2. I/O TEST

- CHECK EVERY BUTTON AND STEP SENSOR, COIN SELECTOR, MONITOR SCREEN, CARD READER AND CAMERA



- INPUT CHECK : CHECK EACH BUTTON AND STEPS SENSOR, COIN SELECTOR MOVEMENT
- SCREEN CHECK : CHECK COLOR DISPLAY STATUS OF MONITOR AND BAD PIXEL
- CARD READER CHECK : CHECK THE CONNECTION AND PERCEIVING STATUS OF CARD READER
- CAMERA CHECK : CHECK THE STATUS OF IMAGE THAT CAMERA IS PHOTO GRAPHING

- INPUT TEST

- CHECK EACH BUTTON AND STEPS SENSOR

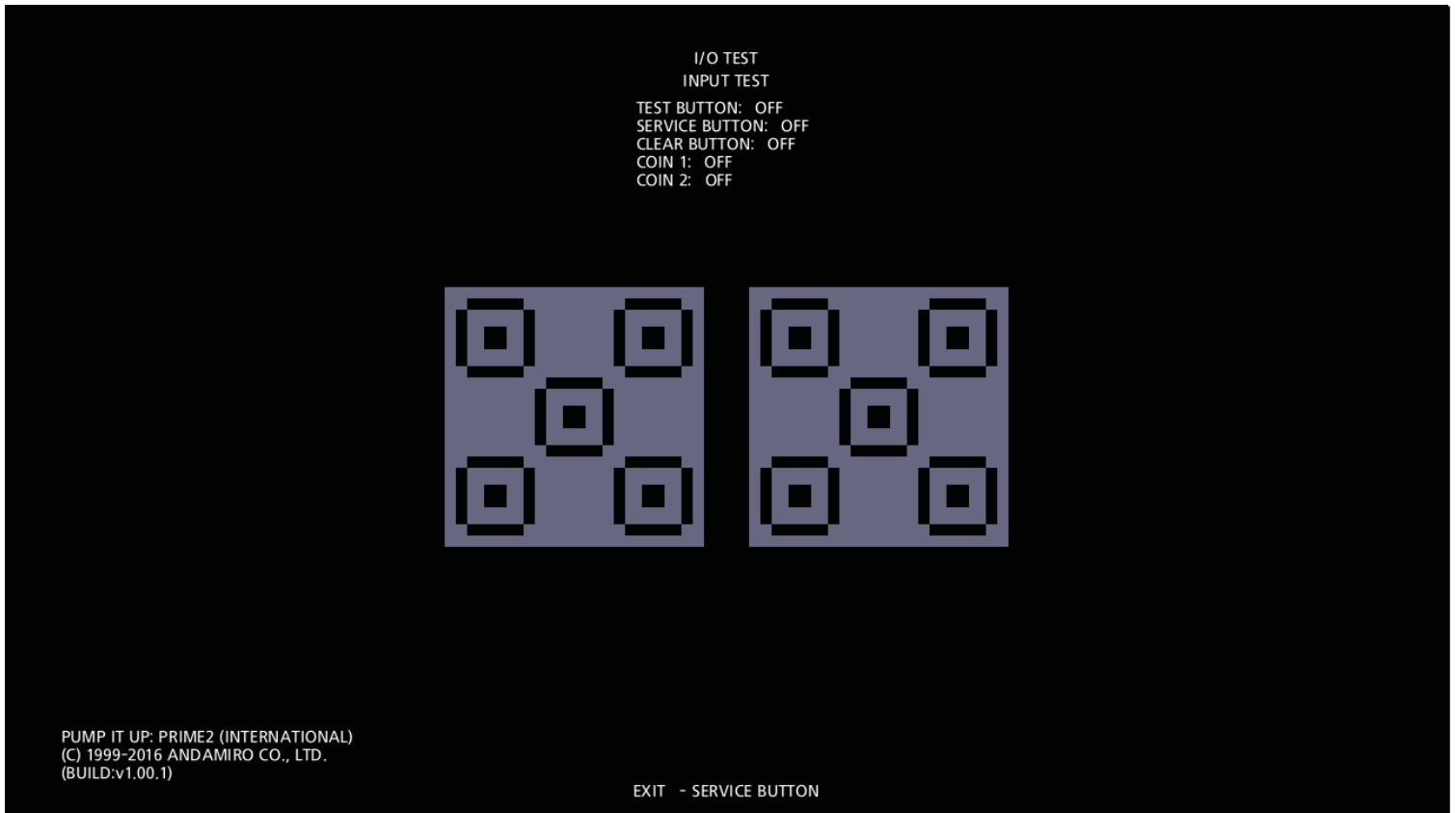





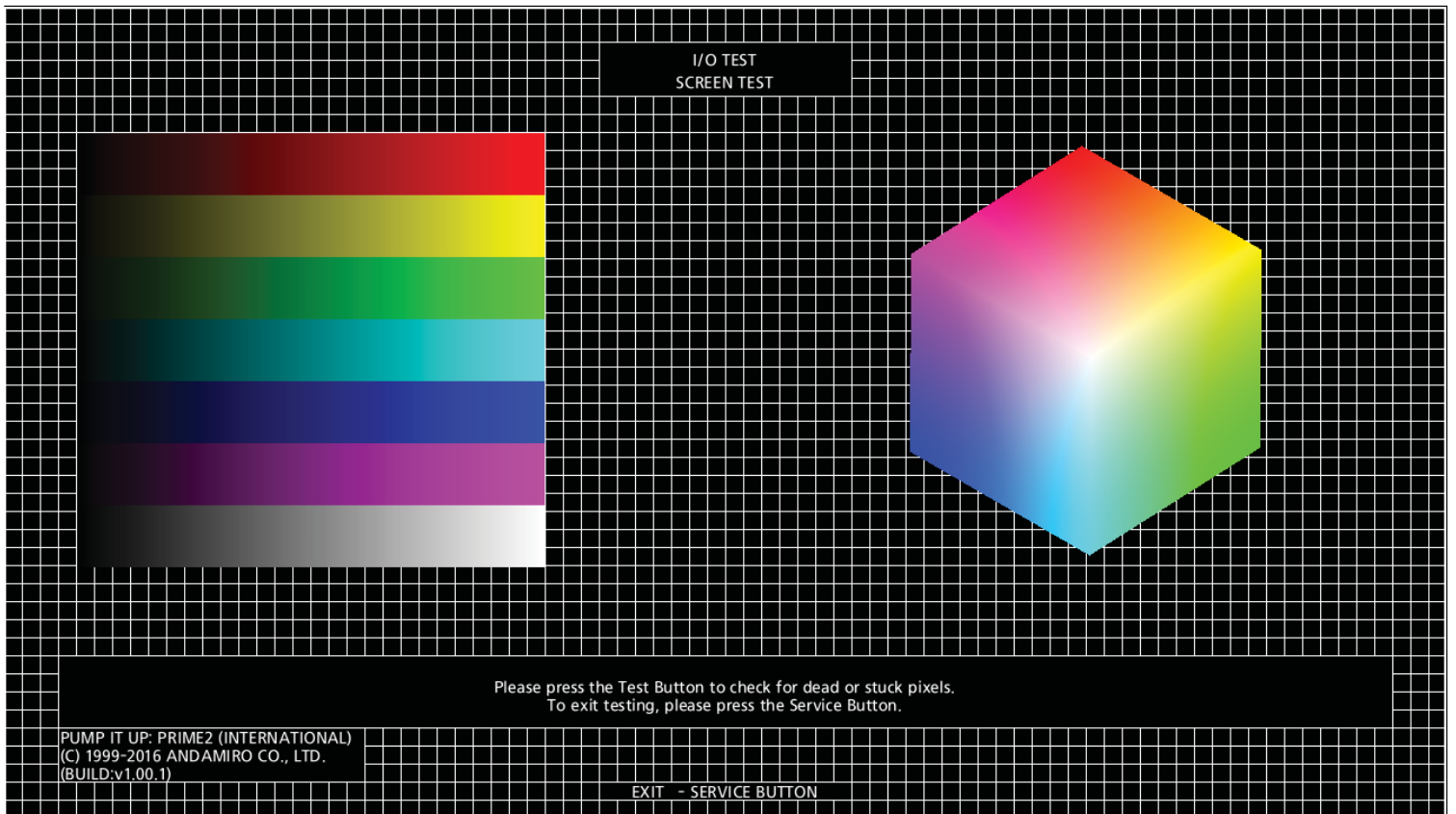

- TEST BUTTON : PUSH BUTTON, OFF BECOMES ON
- SERVICE BUTTON : PUSH BUTTON, OFF BECOMES ON
- COIN1 : INSERT COIN, OFF BECOMES ON
- COIN2 : INSERT COIN, OFF BECOMES ON

- SCREEN TEST

- CHECK THE COLOR DISPLAY AND BAD PIXELS



- BY PUSHING TEST BUTTON, YOU CAN CHECK AS BELOW.

	SCREEN TEST DISPLAY
	SCREEN IS FILLED WITH RED COLOR
	SCREEN IS FILLED WITH GREEN COLOR
	SCREEN IS FILLED WITH BLUE COLOR
	SCREEN IS FILLED WITH WHITE COLOR
	SCREEN IS FILLED WITH BLACK COLOR

5-3. CARD READER CHECK UP

- CHECK THE PERCEIVING STATUS OF CARD READER



- NOT CONNECTED : CARD READER IS NOT CONNECTED TO THE MACHINE
- CONNECTED : CARD READER IS CONNECTED TO THE MACHINE
- CARD READING : CARD READING IS BEING PERCEIVED BY CARD READER

5-4. CAMERA CHECK UP

- CHECK THE STATUS OF IMAGE THAT CAMERA IS PHOTOGRAPHING

I/O TEST
CAMERA TEST



PUMP IT UP: PRIME2 (INTERNATIONAL)
(C) 1999-2016 ANDAMIRO CO., LTD.
(BUILD:v1.00.1)

EXIT - SERVICE BUTTON

5-5. GAME SETTING

- YOU CAN CHANGE VARIOUS SETTING IN GAME



- VIDEO MODE : CHANGE GAME DISPLAY
- GAME MODE : CHANGE GAME MODE
- INITIAL VALUE : CHANGE LIFE NUMBERS ON GAME START
- LEVEL : CHANGE GAME DIFFICULTY
- STAGE BREAK : CHANGE STAGE BRAKE APPLYING TIME
- SELECT TIME : CHANGE SELECTING SONG TIME
- SHOW OPENING : ON AND OFF OPENING DISPLAY
- DEFAULT GAME SETTING : INITIALIZE GAME SET UP VALUE
- SAVE AND EXIT : SAVE THE SET UP VALUE AND EXIT THE MENU

5-6. CREDIT SETTING

- SET COIN NUMBERS FOR PLAYING, LIMIT AND MODE

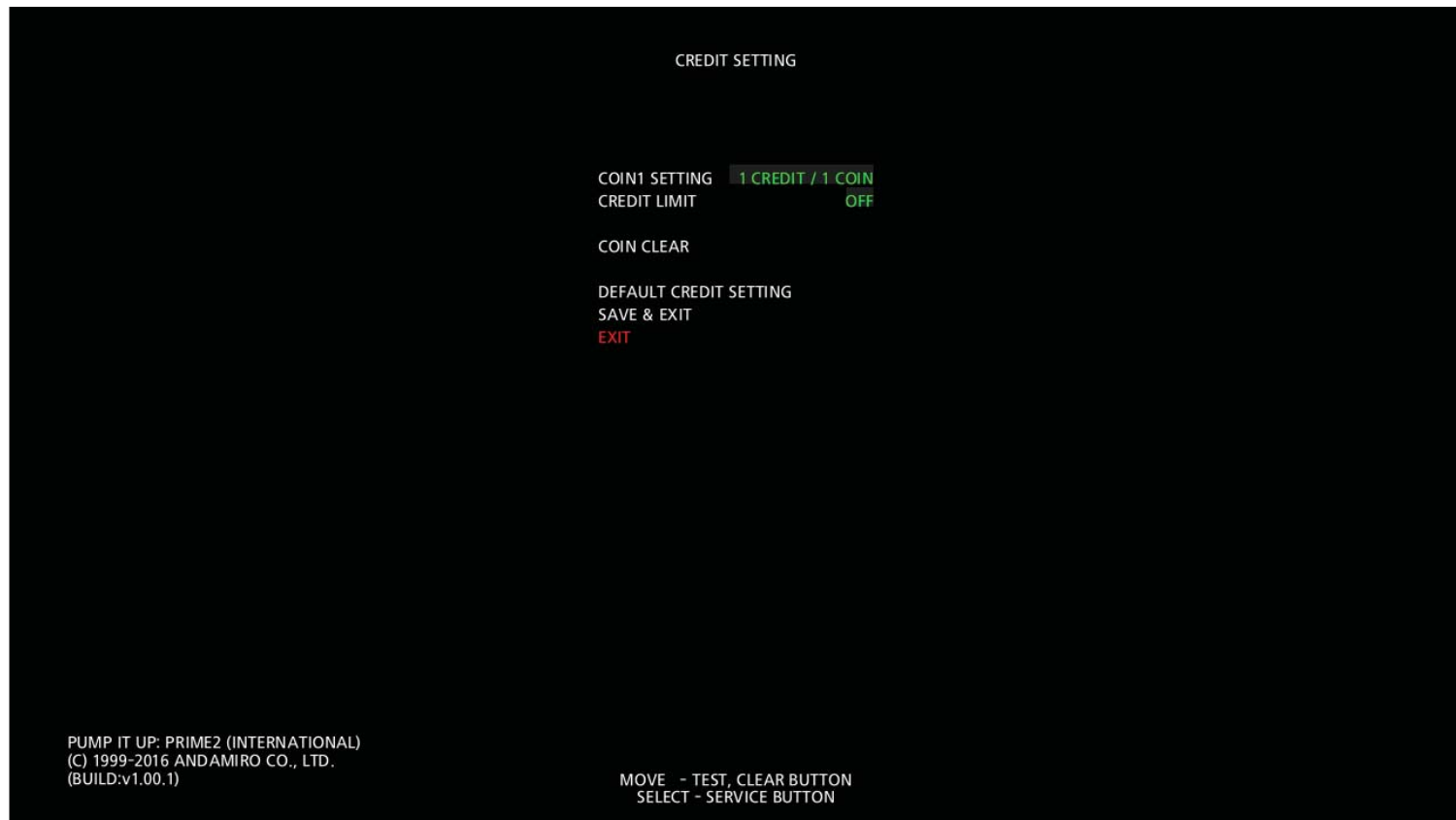

- COIN1 SET : SET COIN NUMBER FOR PLAY
- CREDIT LIMIT : SET CREDIT LIMIT
- COIN CLEAR : INITIALIZING THE INPUT COINS
- DEFAULT CREDIT SETTING : INITIALIZING THE CREDIT SET UP STAUUS
- SAVE AND EXIT : SAVE THE SET VALUE AND EXIT TO MENU

5-7. USB DRIVE

- YOU CAN DO SYSTEM UPDATE AND SET USB



- PLAYER 1 : SET THE USB OF 1P PLAYER
- PLAYER 2 : SET THE USB OF 2P PLAYER
- SYSTEM UPDATE : SYSTEM UPDATE
- SAVE AND EXIT : SAVE THE SET VALUE AND EXIT TO MENU

5-8. CARD READER

- YOU CAN SET THE CARD READER

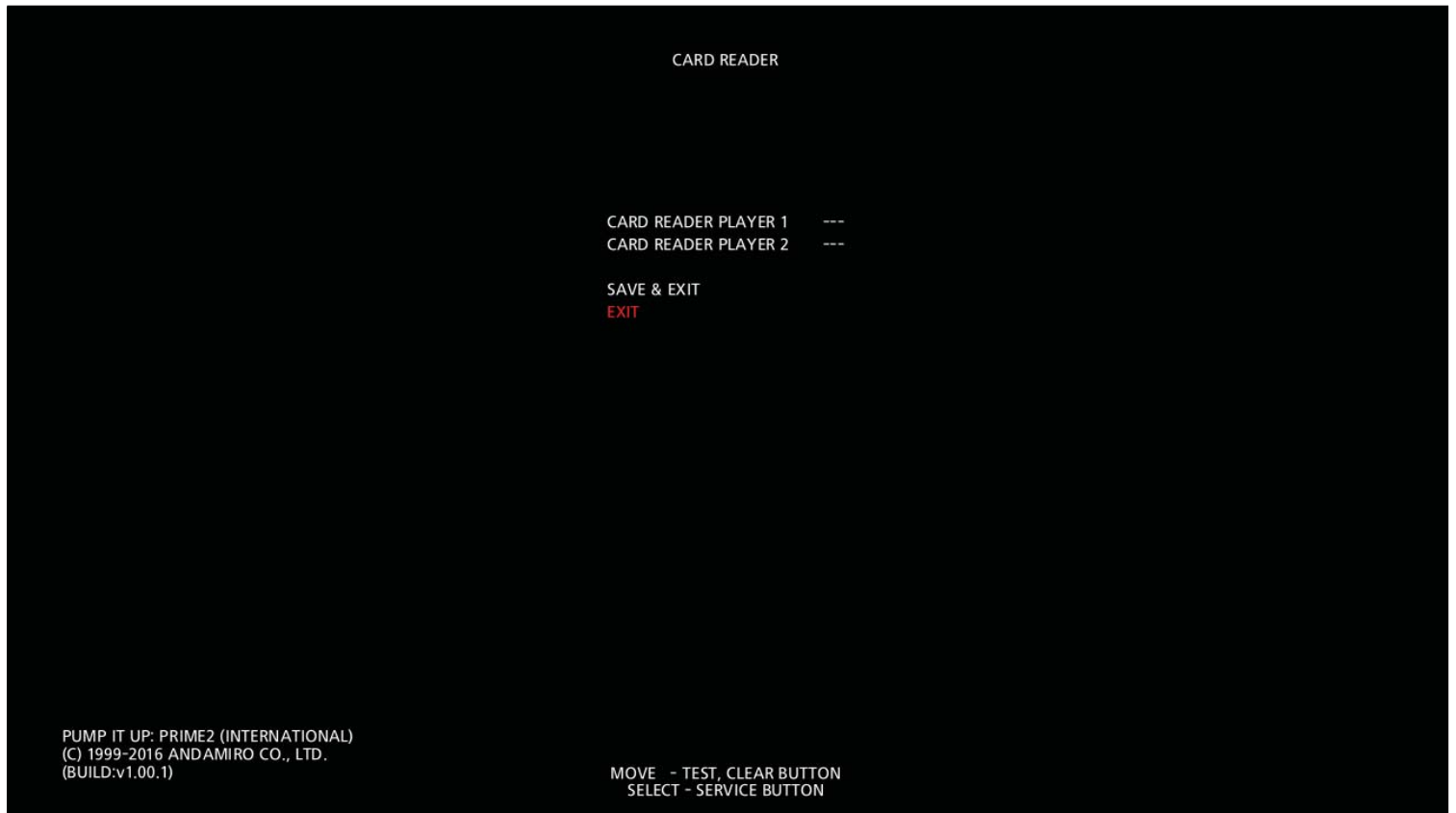

- CARD READER PLAYER 1 : SET THE CARD READER FOR 1P PLAYER
- CARD READER PLAYER 2 : SET THE CARD READER FOR 2P PLAYER
- SAVE AND EXIT : SAVE THE SETTING AND EXIT

[Card reader Player 1, Card reader Player 2]

You can set the card reader by activating the card reader

Activate the card reader in following sequence

1. Wait at the point of card reader Player 1 in Card Reader Menu
2. Put AM PASS Card to the card reader on the Left Side of the machine
3. Press Test Button at card reader player 1
4. Wait at the point of card reader player 2 in card reader menu
5. Put AM PASS Card to the card reader on the Right Side of the machine
6. Press Test button at card reader player 2
7. Save the settings and exit and then card reader shall be activated to perceive AM PASS Card

Note: According to the machine, the location of Card Reader can be different or there may be no location for Card Reader

5-9. SOUND SETTING

- YOU CAN PLAY THE LIST SONG, SPEAKER CHECKING AND GAME ENVIRONMENT VOLUME



- GAME VOLUME : ADJUST GAME VOLUME
- DEMO VOLUME : ADJUST DEMO SCREEN
- DEMO PLAY : SET THE WAY OF DEMOPLAY SOUND PLAY
- SPEAKER TEST : CHECK SPEAKERS
- DSP SETTING : SET THE SOUND OUTPUT IN OPTIMUM CONDITION
- AUDIO : PLAY THE LISTED SONGS
- DEFAULT SOUND SETTING : INITIALIZE SOUND SETTING STATUS AS BEGINNING STATUS
- SAVE AND EXIT : SAVE THE SETTING VALUE AND EXIT TO MENU

Note: Please do this test at GAME VOLUME = 80 from SOUND SETTING DSP.
Set GAME VOLUME to 80 and go to DSP TEST and then play until 1 khz beep sound is ended.

*** Please be sure to do it when changing the sound volume in test mode or changing DSP.**

- Please do it in following sequence.
 1. Set the sound volume of the game to play
 2. Please wait till the sound ends after pressing DSP setting
 3. Save and Exit

5-10. BOOKKEEPING

- YOU CAN INITIALIZE THE SERVICE COUNT, COIN COUNT AND INCOME STATISTIC



- SERVICE : CHECK SERVICE COUNT
- COIN 1 : CHECK COIN COUNT
- RESET BOOKKEEPING : INITIALIZE SERVICE, COIN COUNT
- RESET RANKING : INITIALIZING RANKINGS
- SAVE AND EXIT : SAVE THE SETTING VALUE AND EXIT TO MENU

5-11. STATISTICS

- YOU CAN CHECK THE INFORMATION SUCH AS PLAYING TIME OF MACHINES, PLAY NUMBERS, FAVORITE SONGS AND MODE

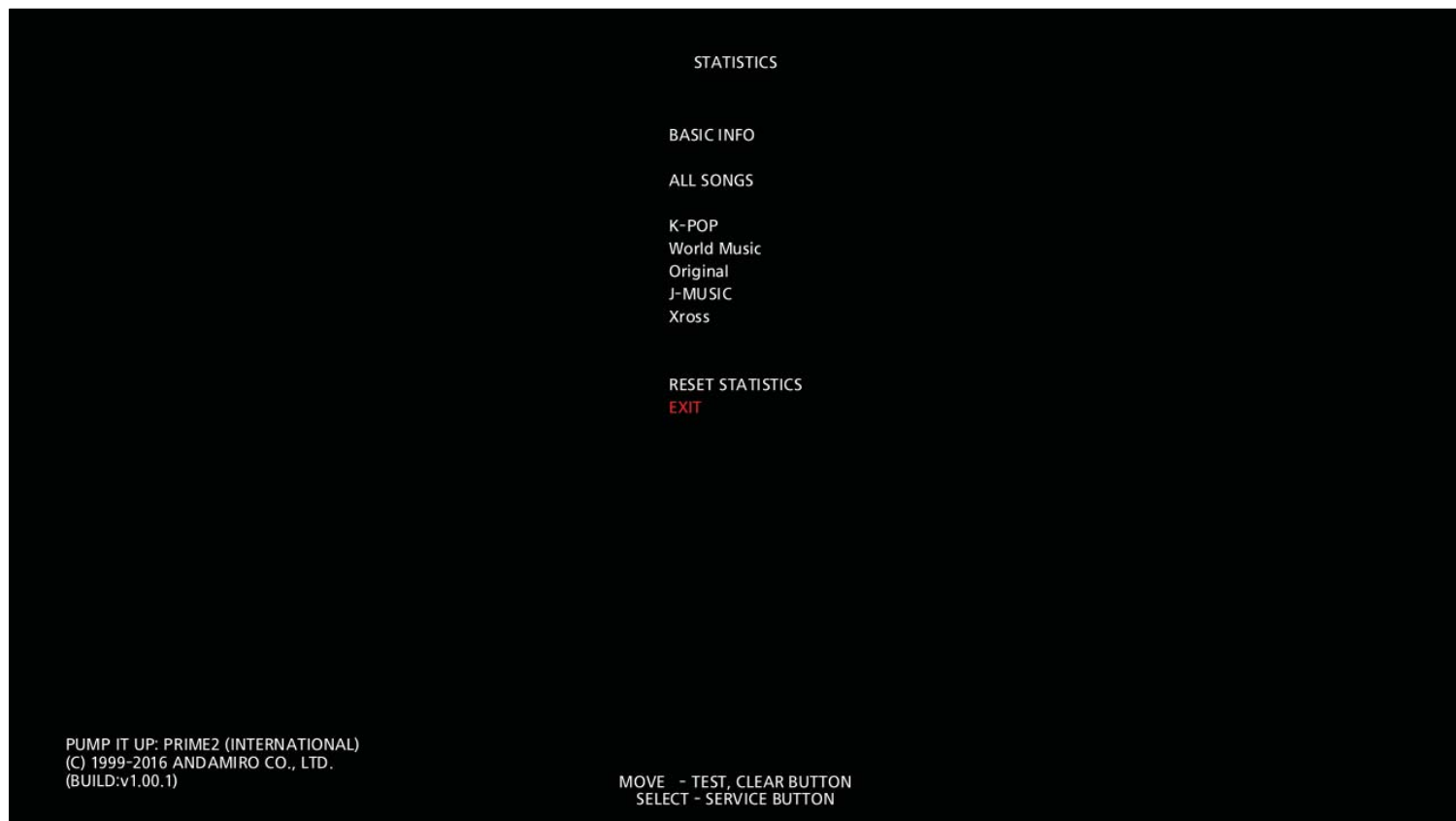

- BASIC SONG : CHECK PLAYING TIME, MACHINE OPERATING TIME
- ALL SONGS : CHECK PLAY COUNT OF ALL SONGS
- K-POP : CHECK PLAY COUNT OF K-POP
- WORLD MUSIC : CHECK PLAY COUNT OF WORLD MUSIC
- ORIGINAL : CHECK PLAY COUNT OF PIU ORIGINAL
- J-MUSIC : CHECK PLAY COUNT OF J-MUSIC
- XROSS : CHECK PLAY COUNT OF XROSS
- RESET STATISTICS : INITIALIZE THE STATISTICS

5-12. RESTRICTION

- YOU CAN RESTRICT SONGS ON THE LIST AND PROHIBIT PLAYING

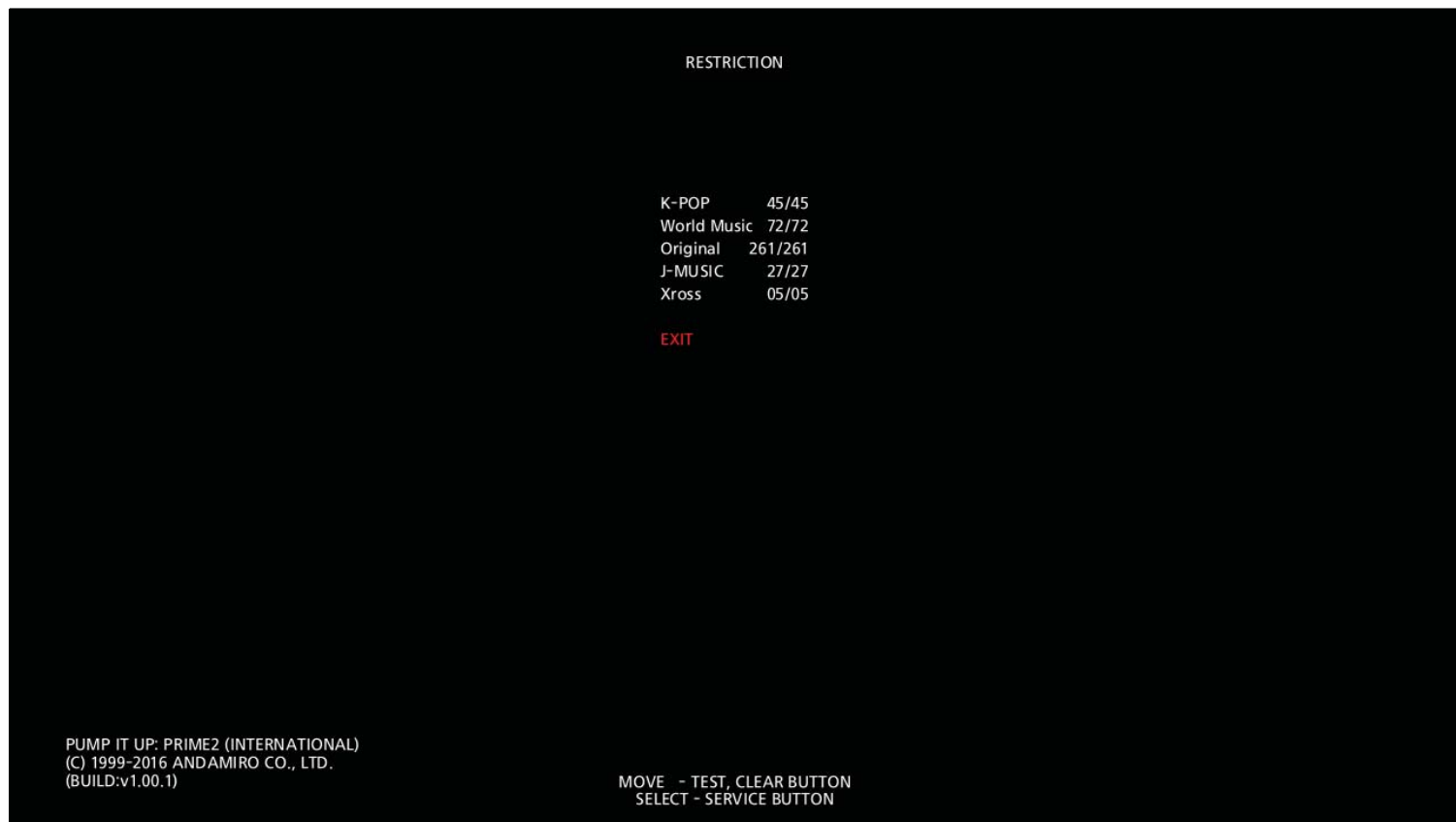

- K-POP : PROHIBIT PLAYING AMONG K-POP
- WORLD MUSIC : PROHIBIT PLAYING AMONG WORLD MUSIC
- ORIGINAL : PROHIBIT PLAYING AMONG PIU ORIGINAL
- J-MUSIC : PROHIBIT PLAYING AMONG J-MUSIC
- XROSS : PROHIBIT PLAYING AMONG XROSS

5-13. FACTORY SETTING

- YOU CAN INITIALIZE THE ENVIRONMENT SETTING STATUS AS FACTORY SETTING

! ALL DATA WILL BE INITIALIZED SO CAREFULLY INITIALIZE IT



6. TROUBLESHOOTING

6-1. MONITOR

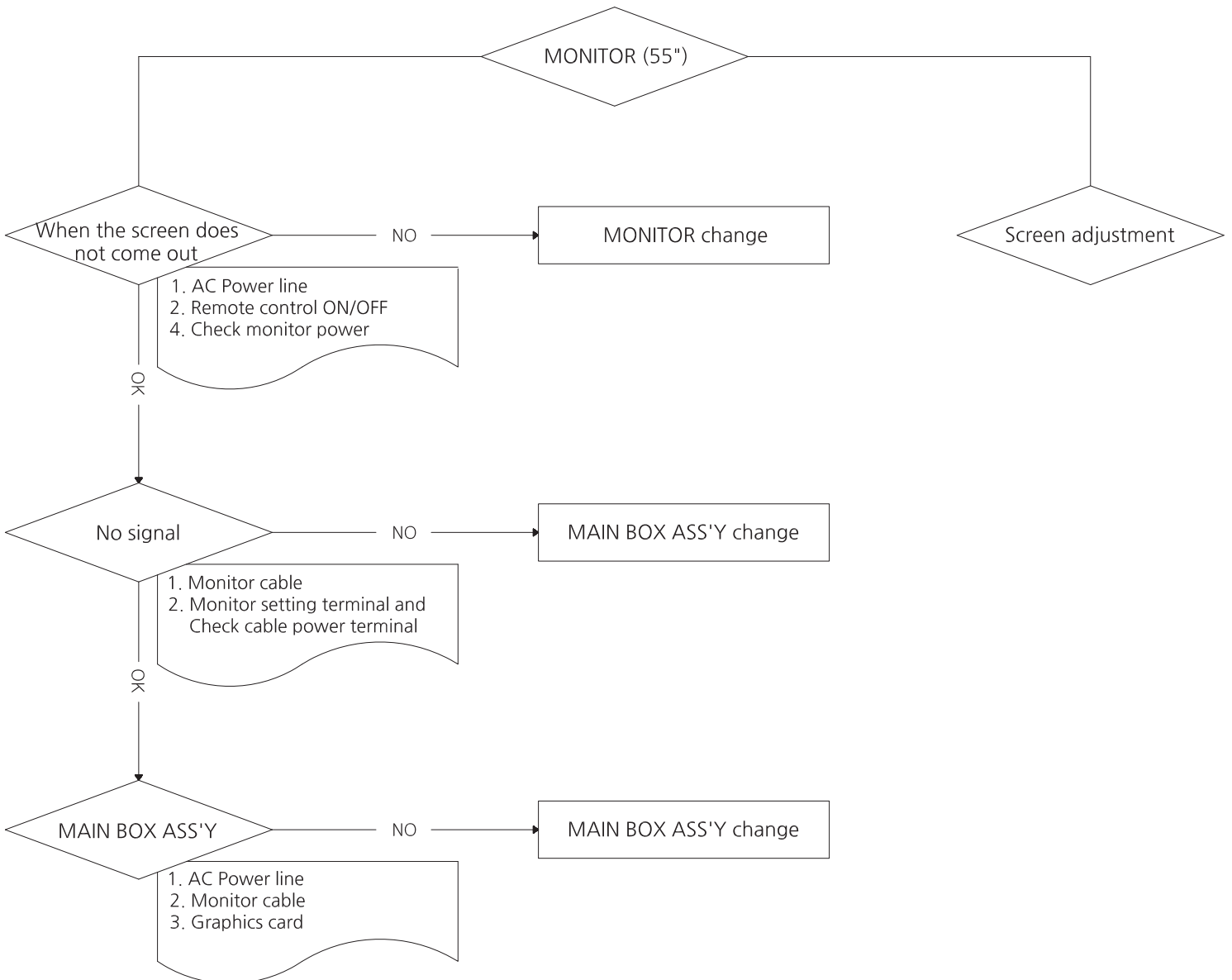
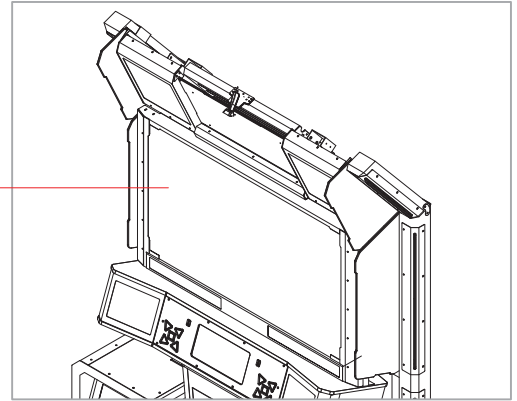

6-2. BUTTON

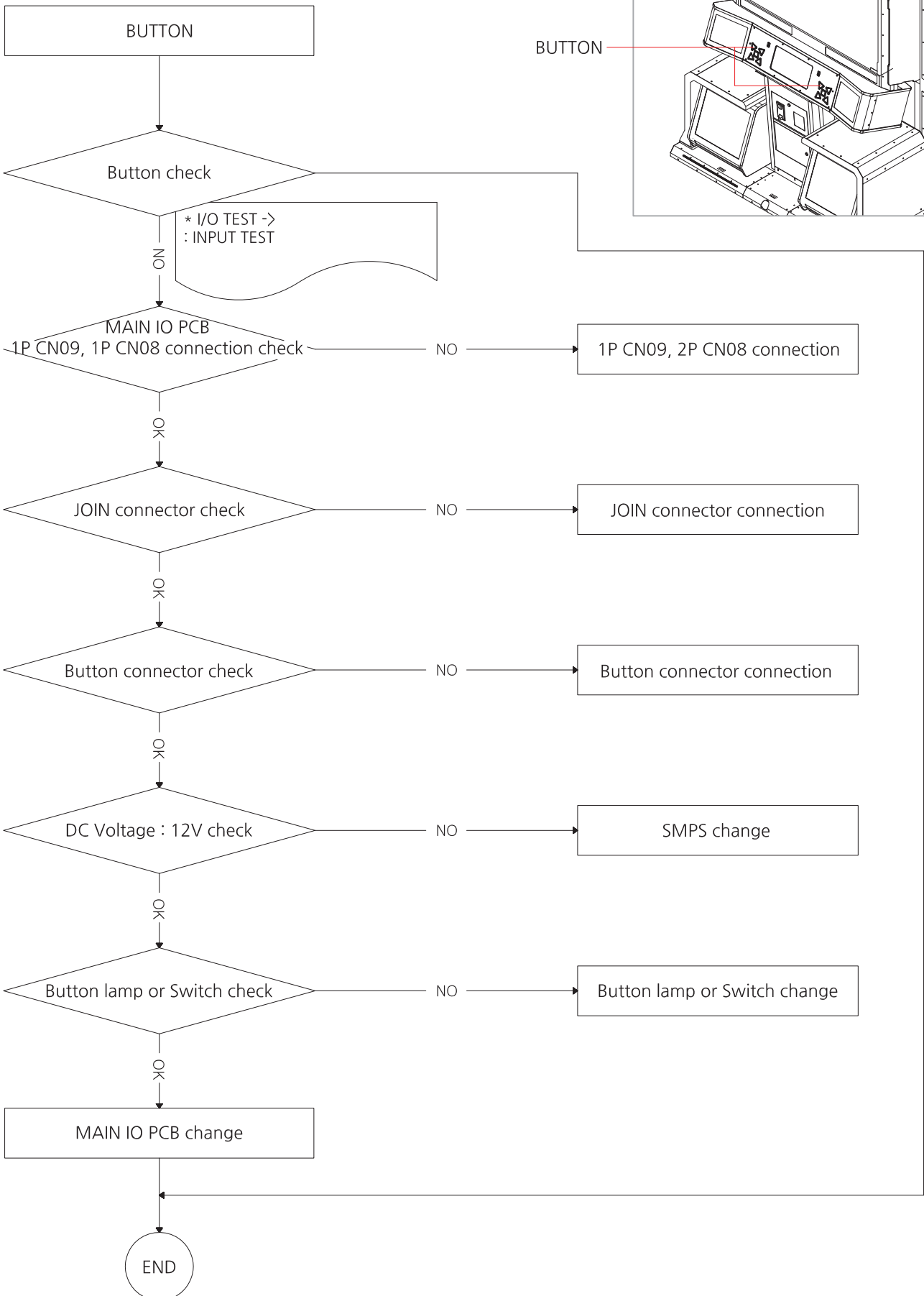

6-3. STEP SENSOR

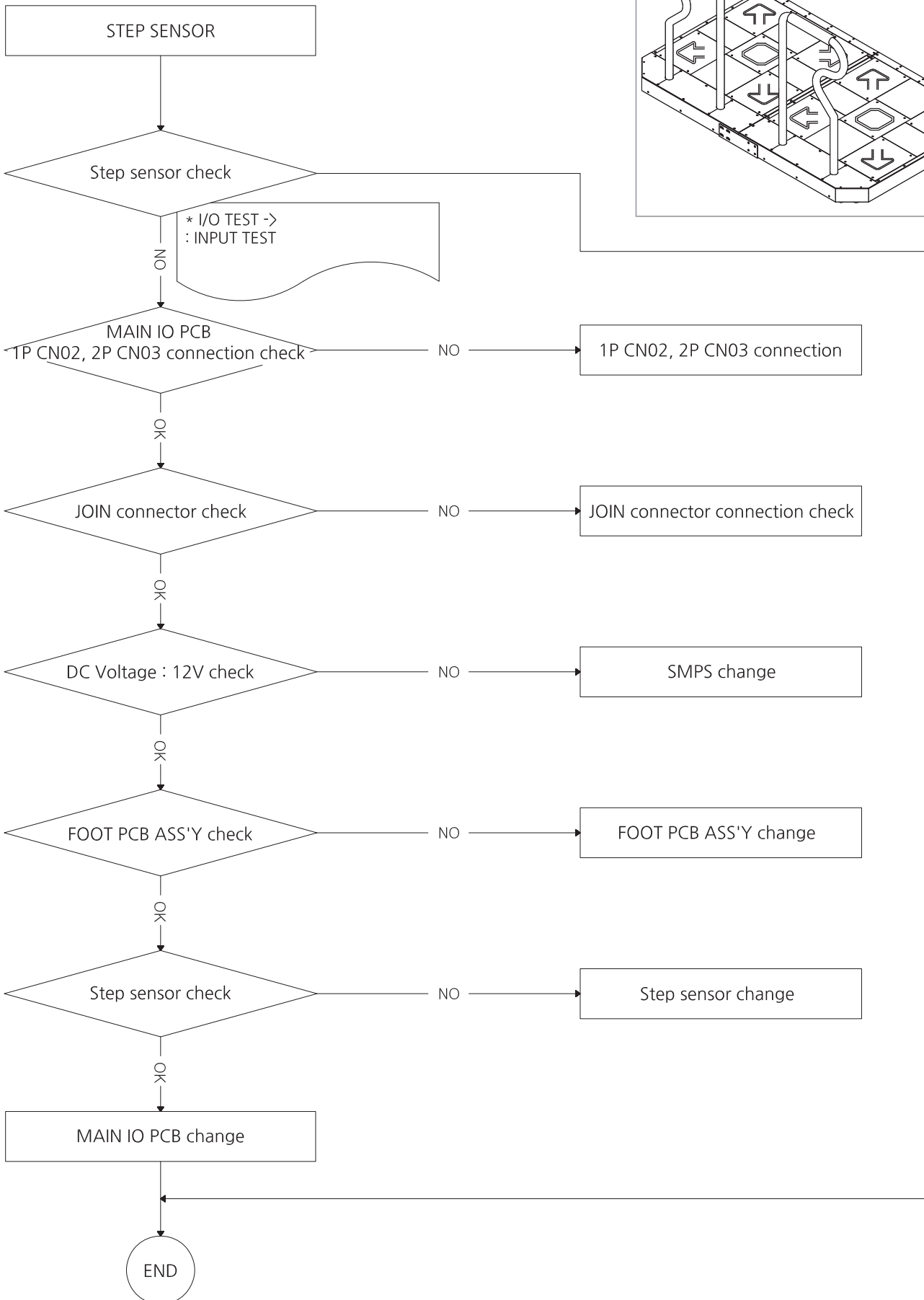
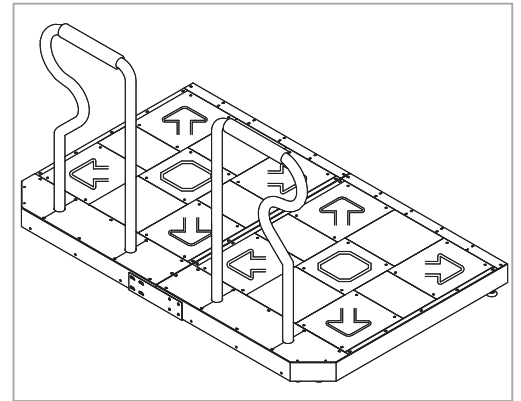

6-4. STEP LED

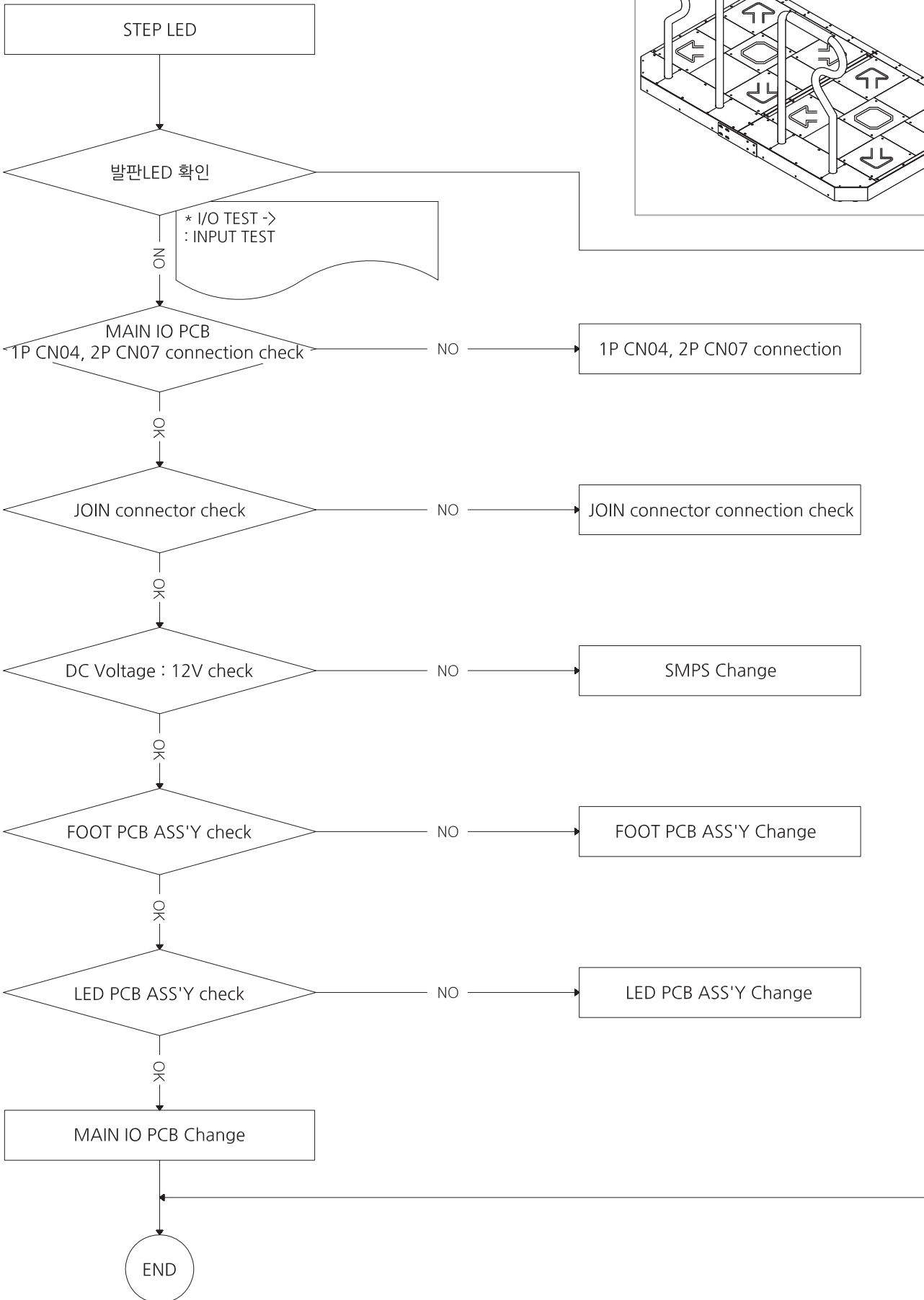

6-5. COIN SELECTOR

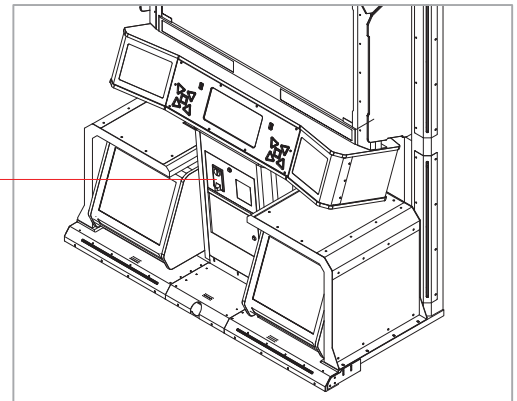
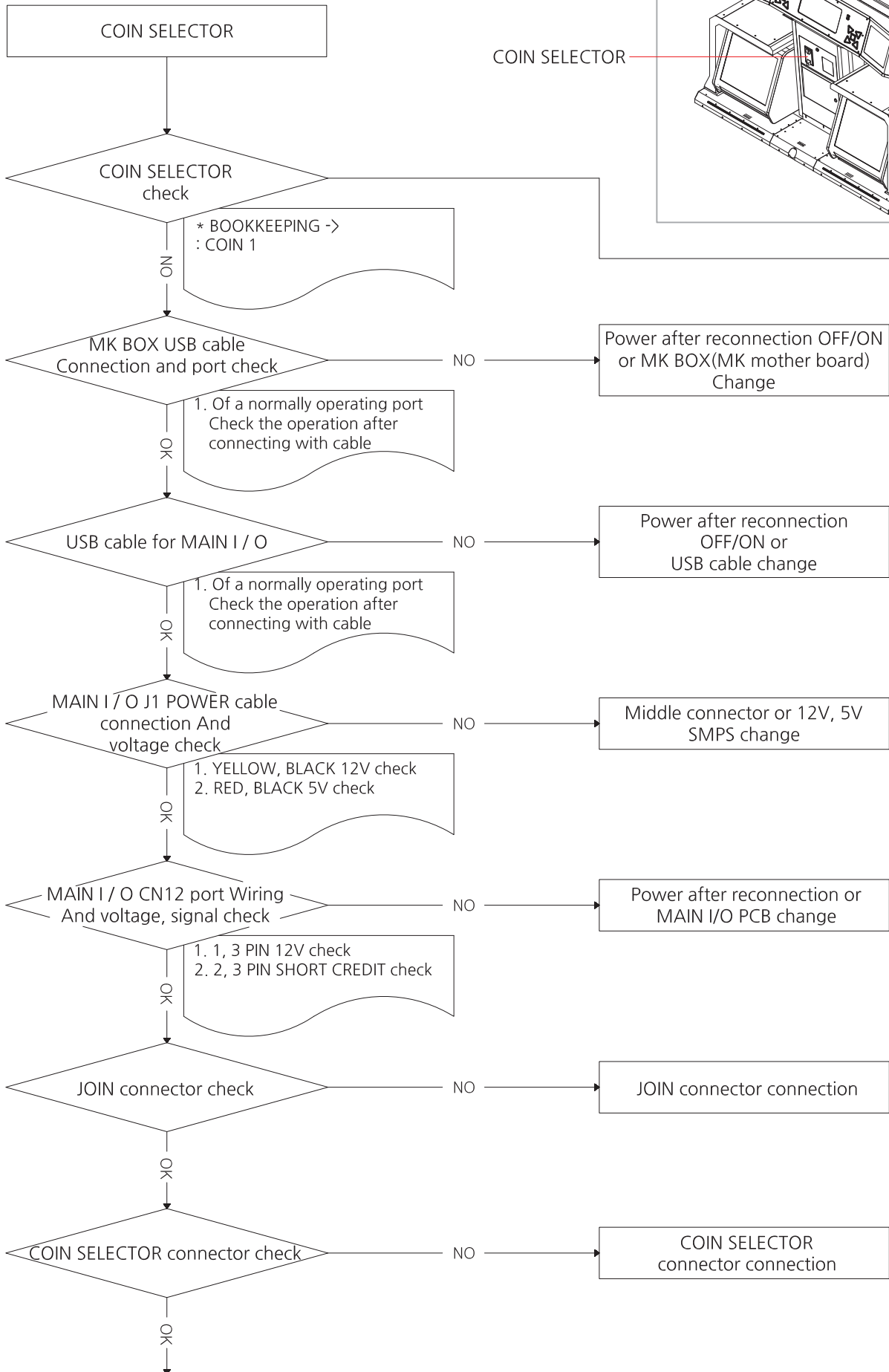

COIN SELECTOR change

END

6-6. WHEN INTERNET COMMUNICATION DOES NOT WORK

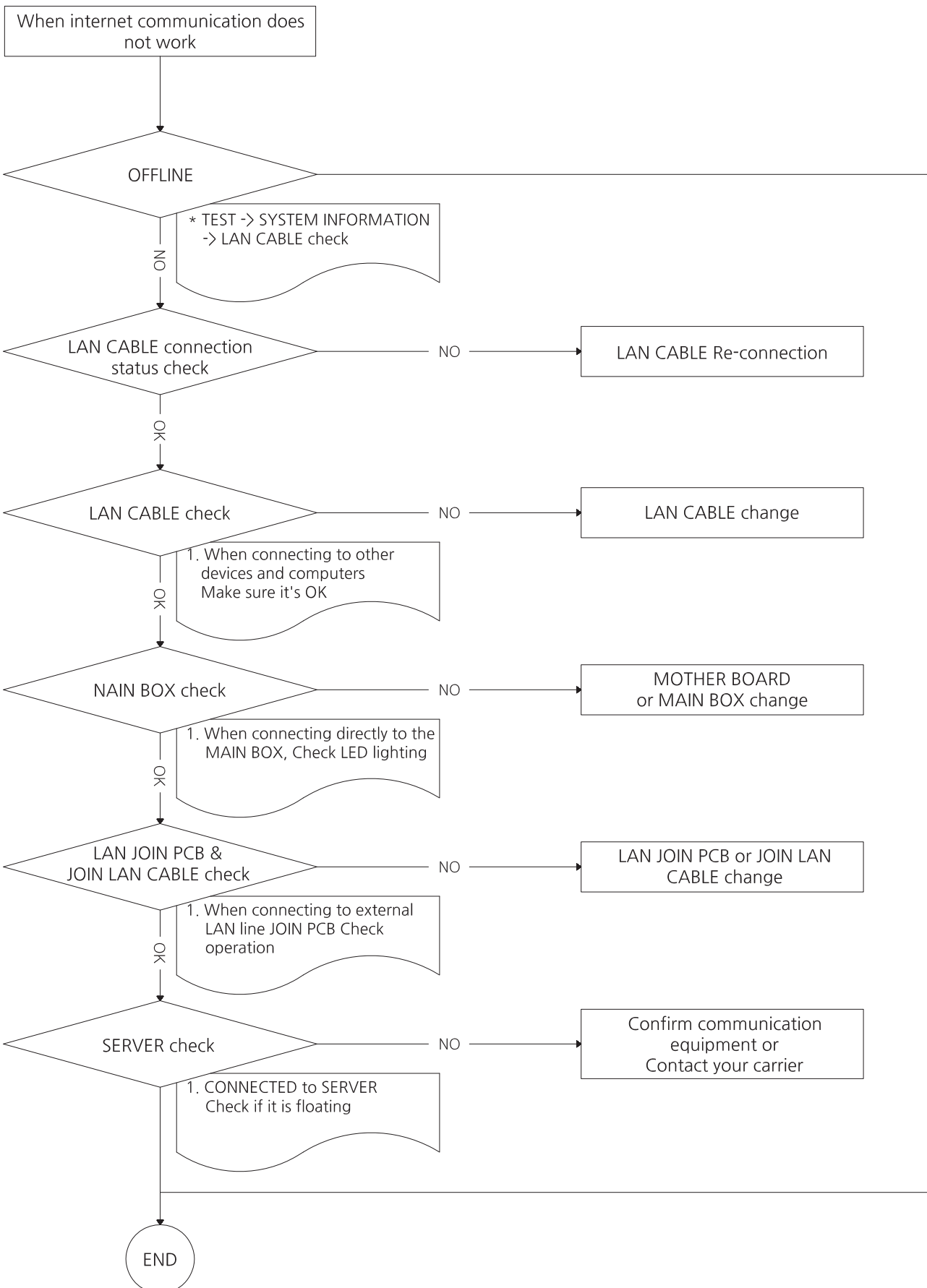

6-7. USB ON/OFF ERROR

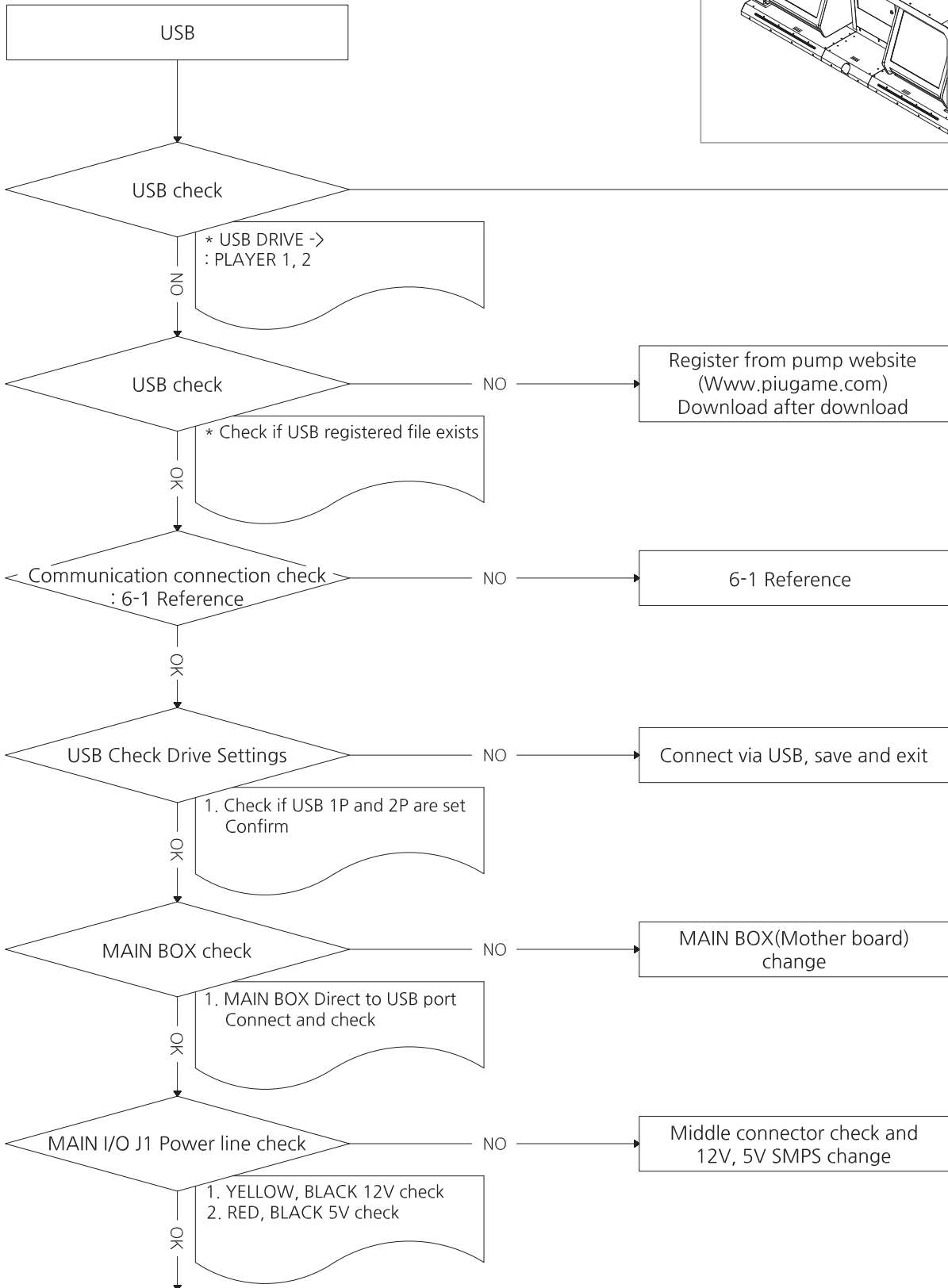
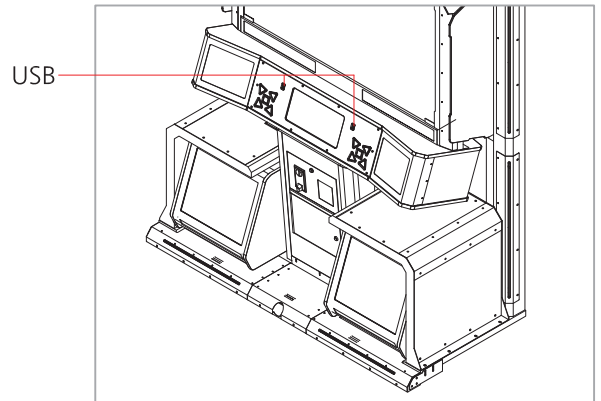

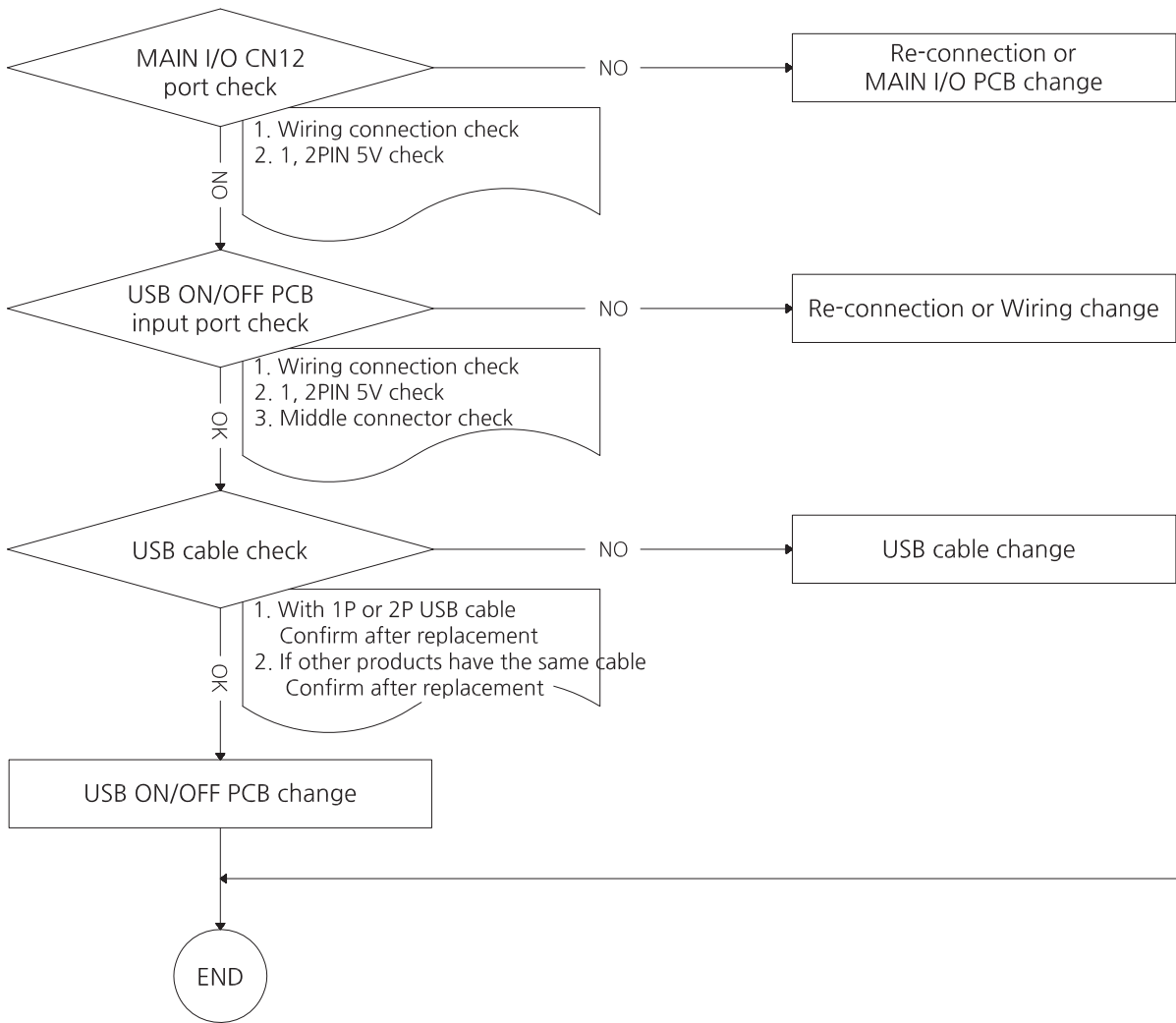

6-8. CARD READER ERROR

CARD READER

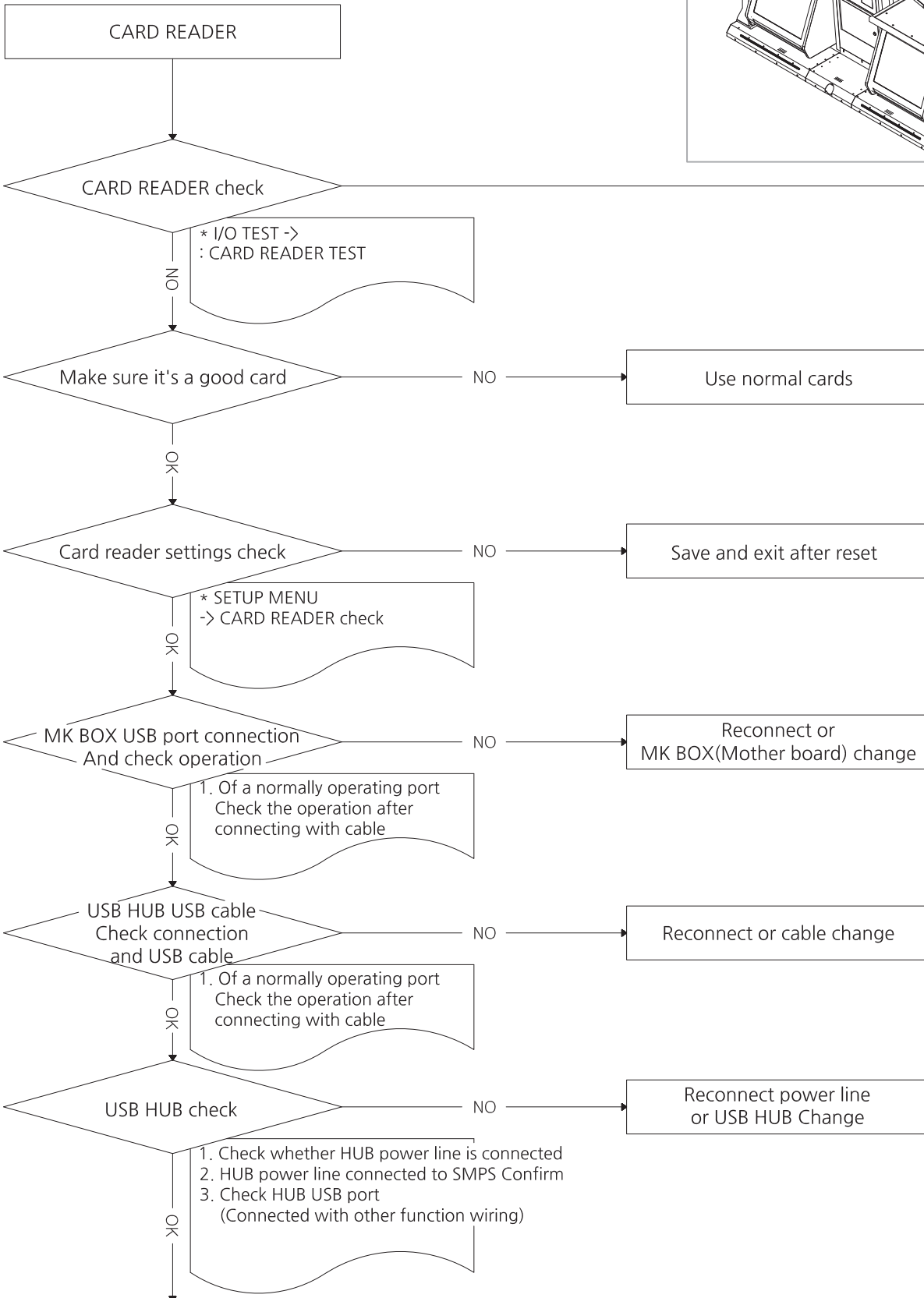
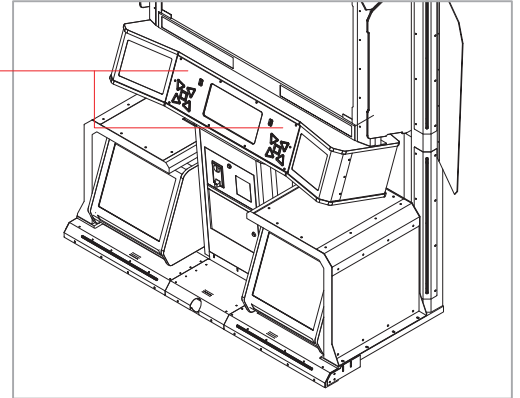

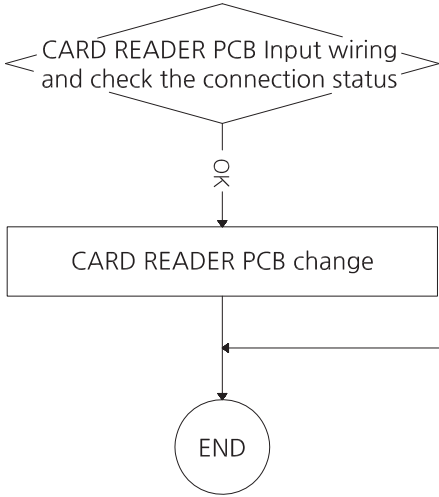

6-9. WEB CAM ERROR

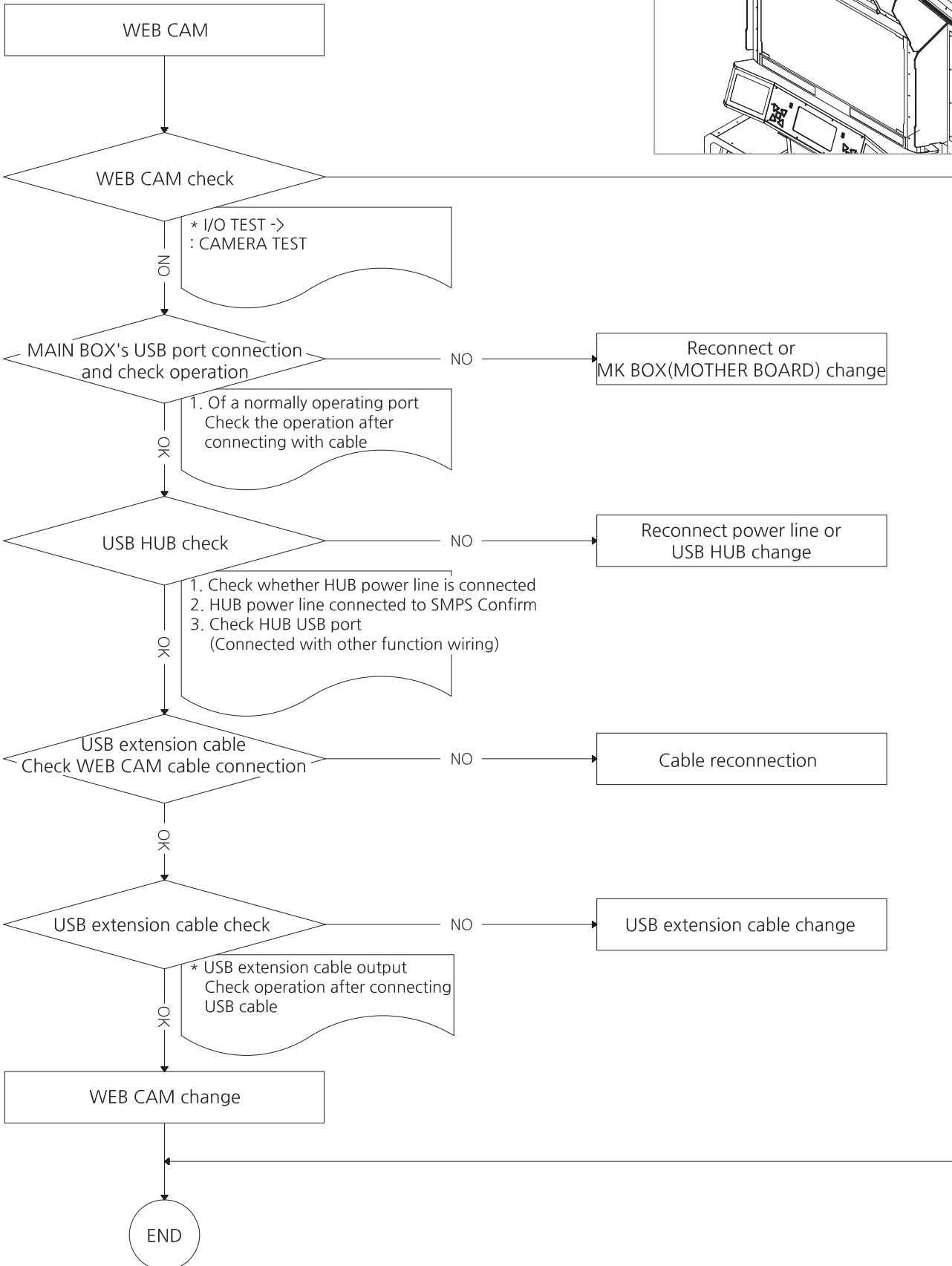
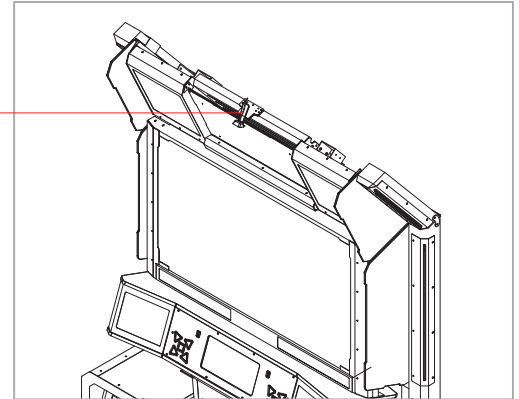

6-10. BILLBOARD LED ERROR

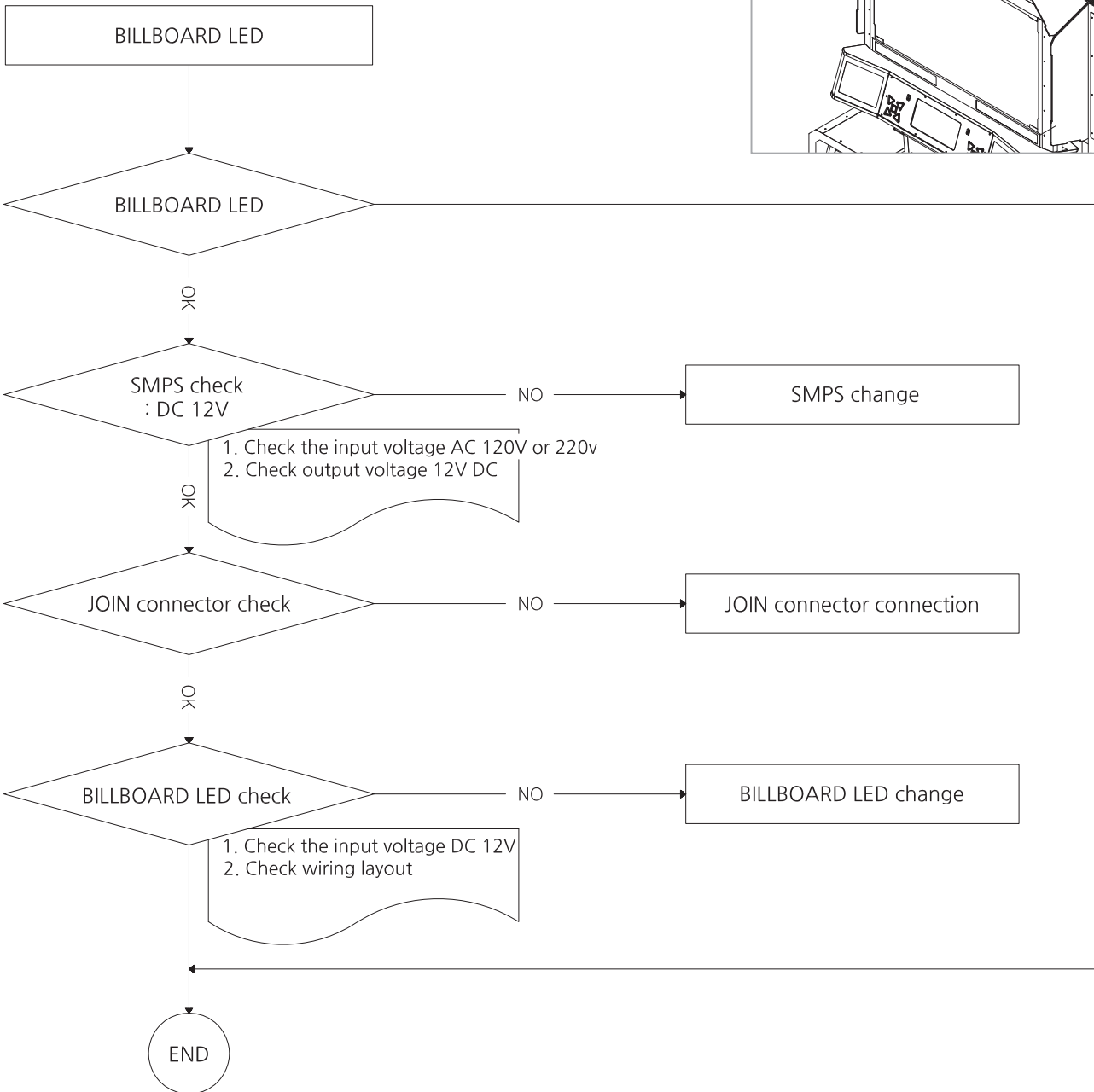
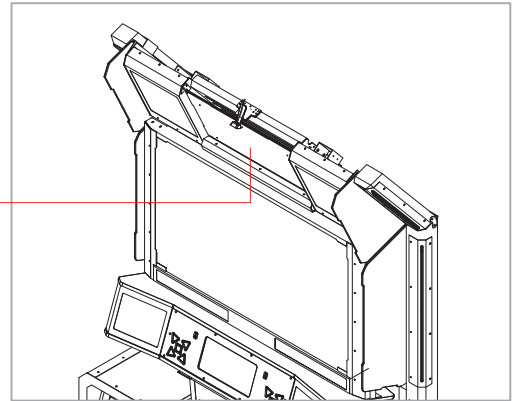

6-11. MIDDLE LED PCB ERROR_CENTER (all)

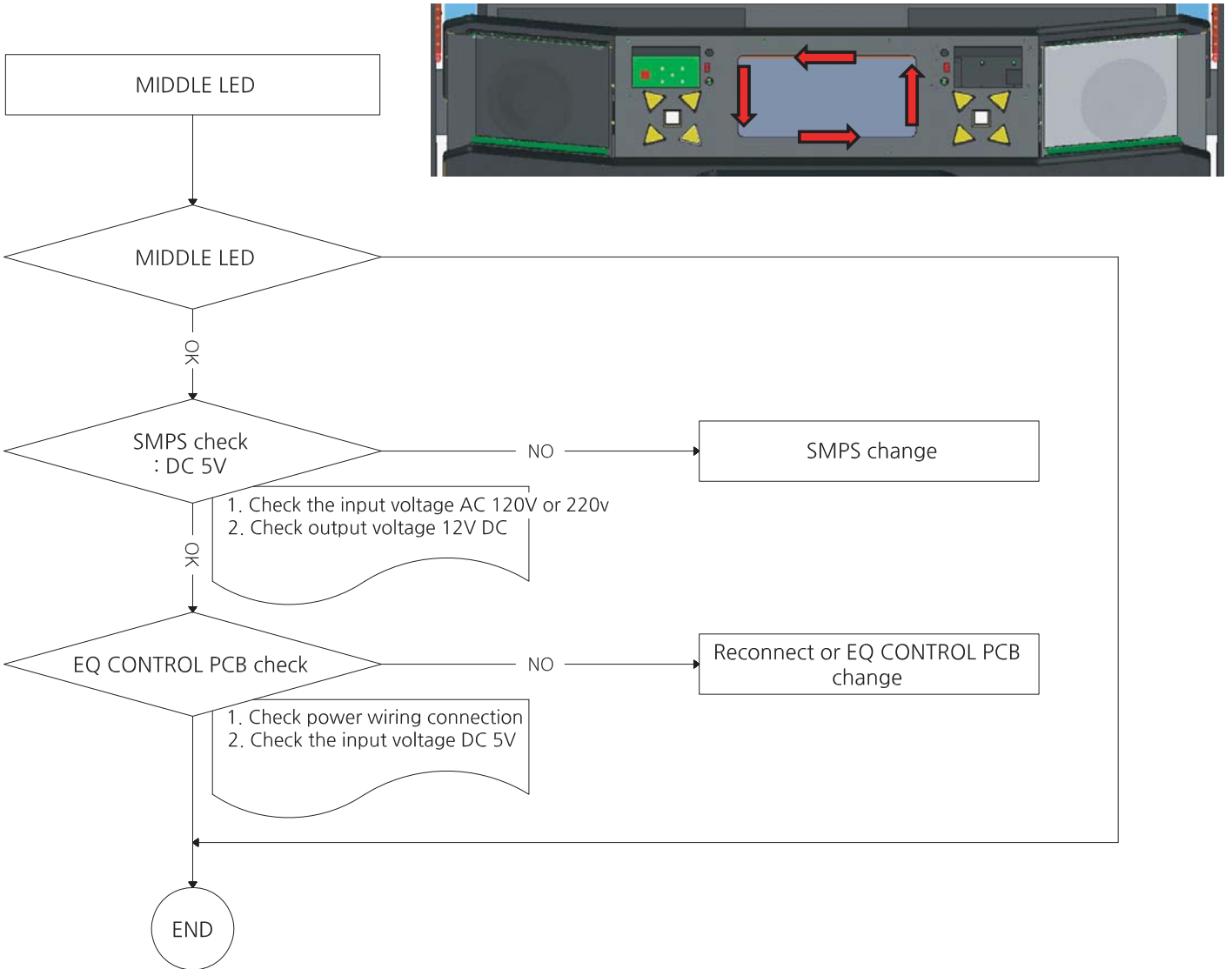

6-12. MIDDLE LED PCB ERROR_L,R (all)

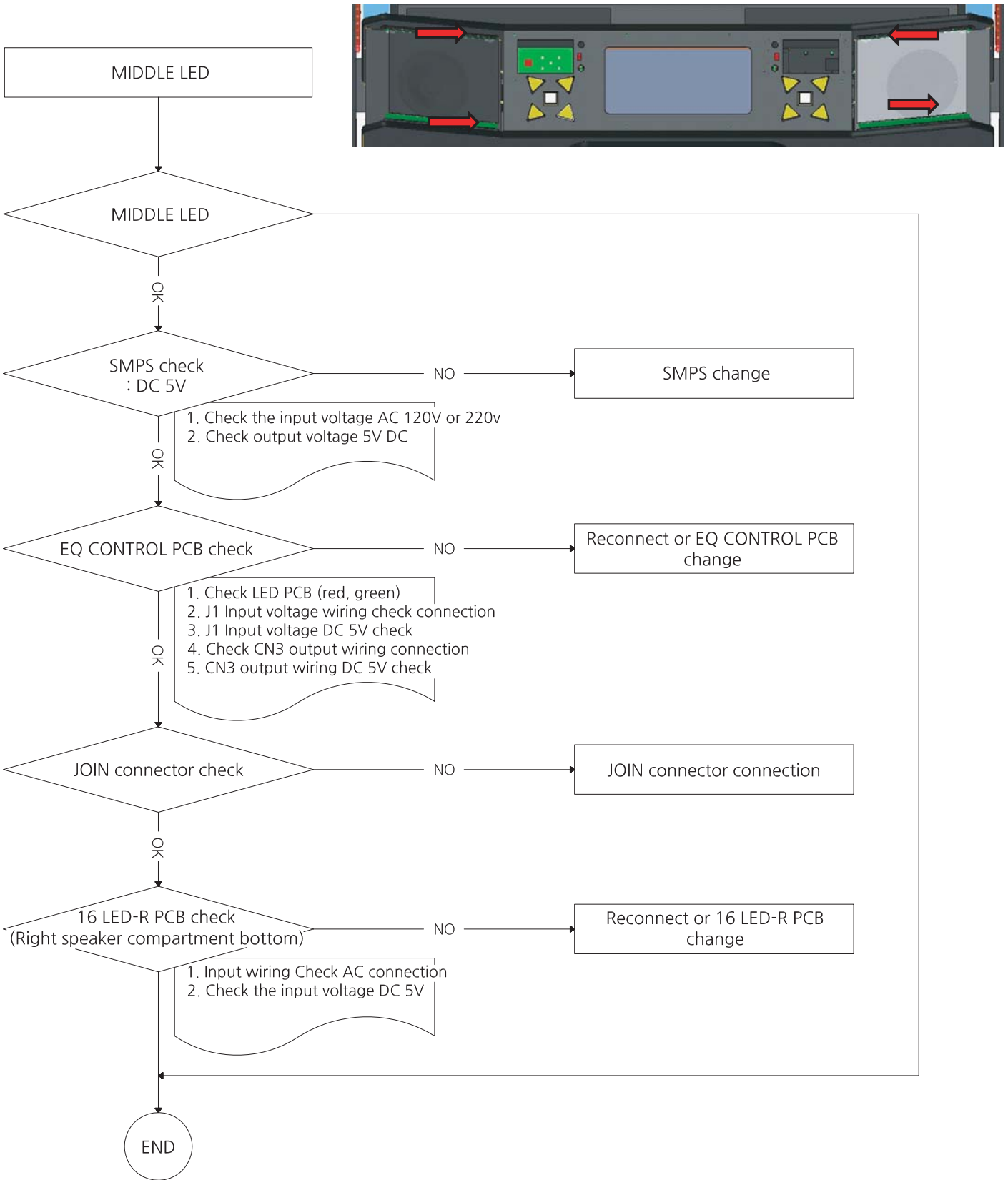

* MIDDLE LED PCB ERROR (part)

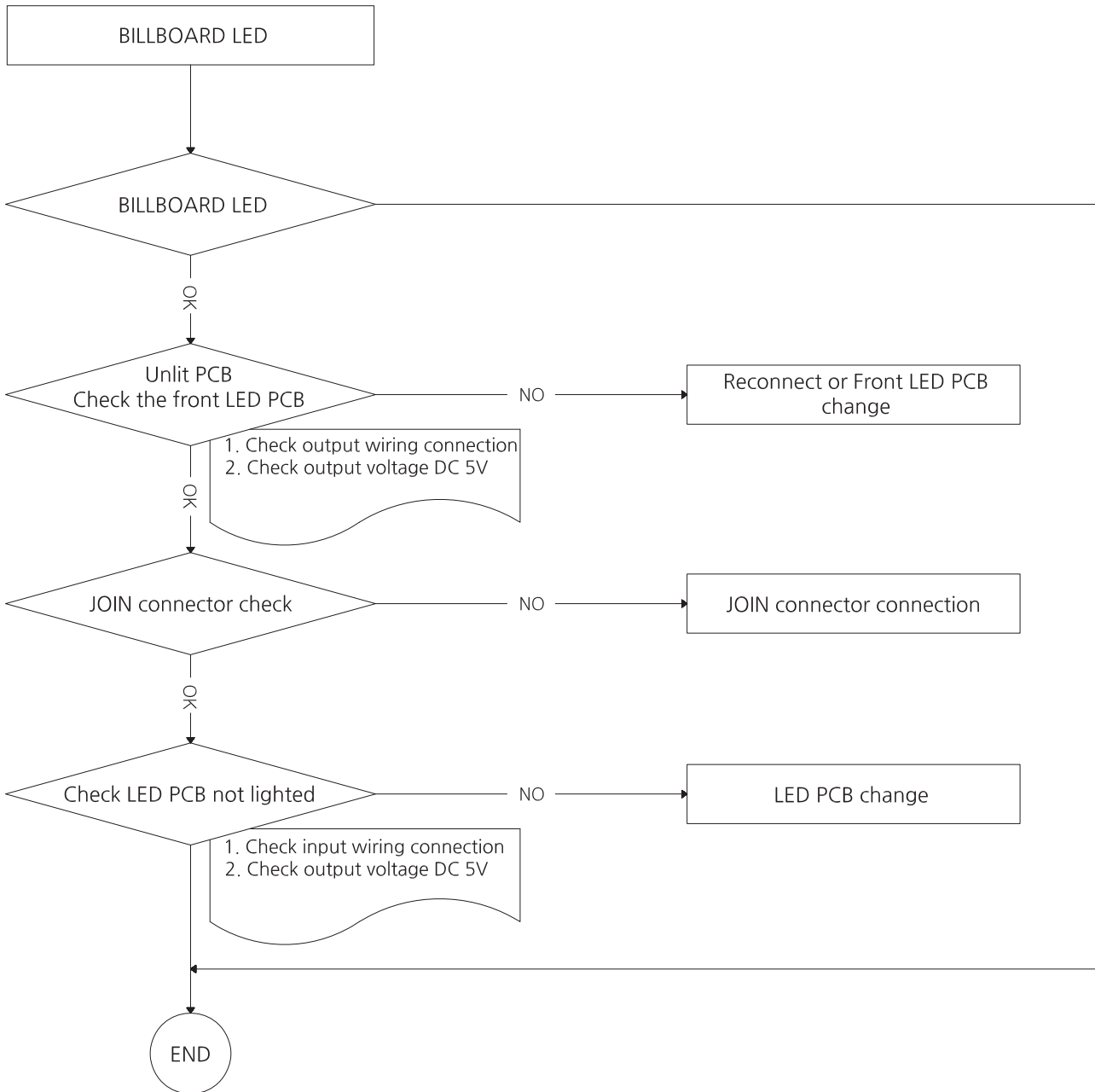

* LED DOT Only one color is wrong or not lit - Replace corresponding LED or replace LED PCB

6-13. BILLBOARD LED PCB ERROR (all)

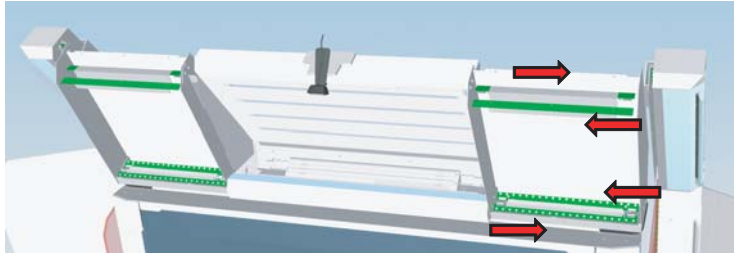
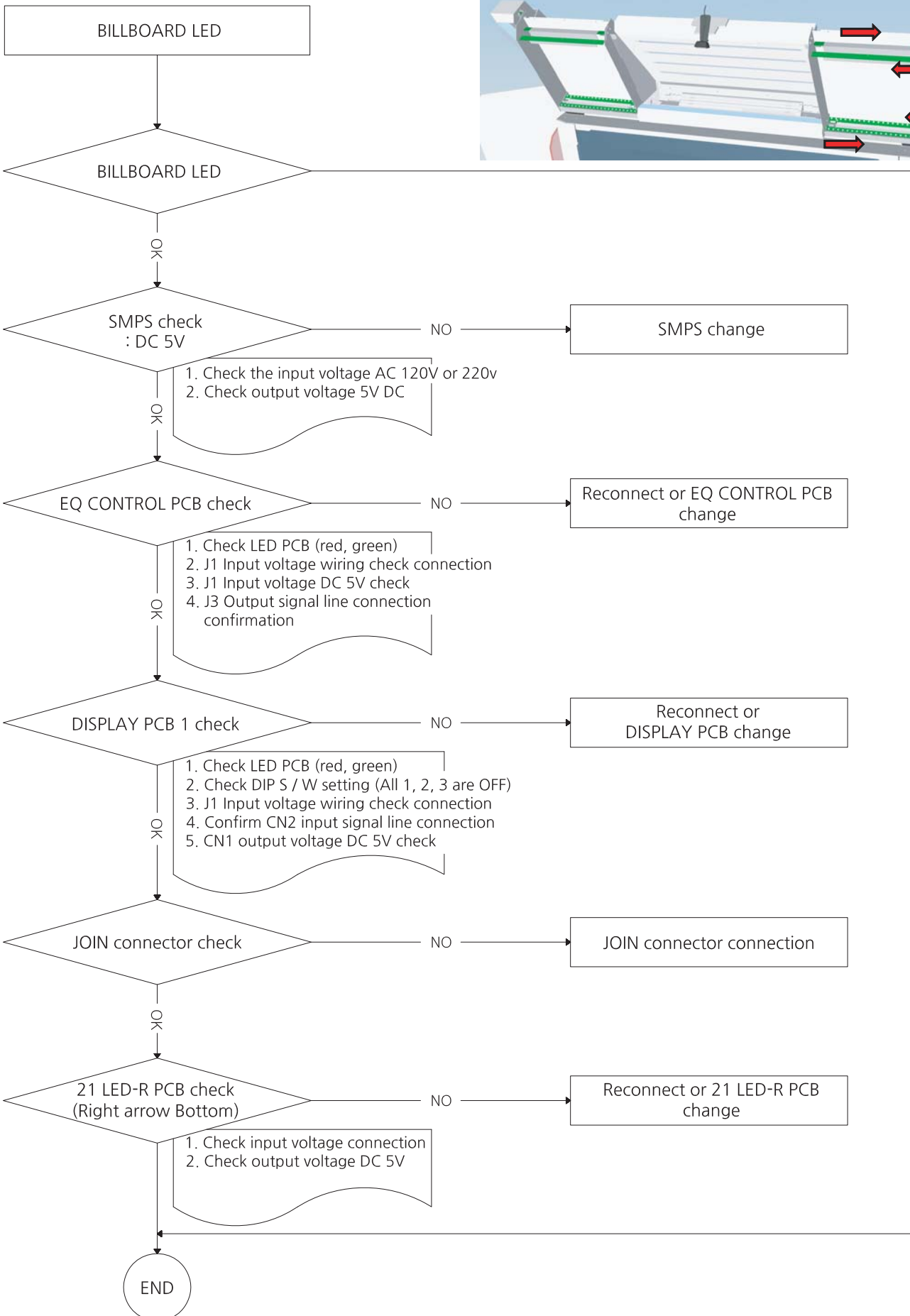

* BILLBOARD LED PCB ERROR (part)

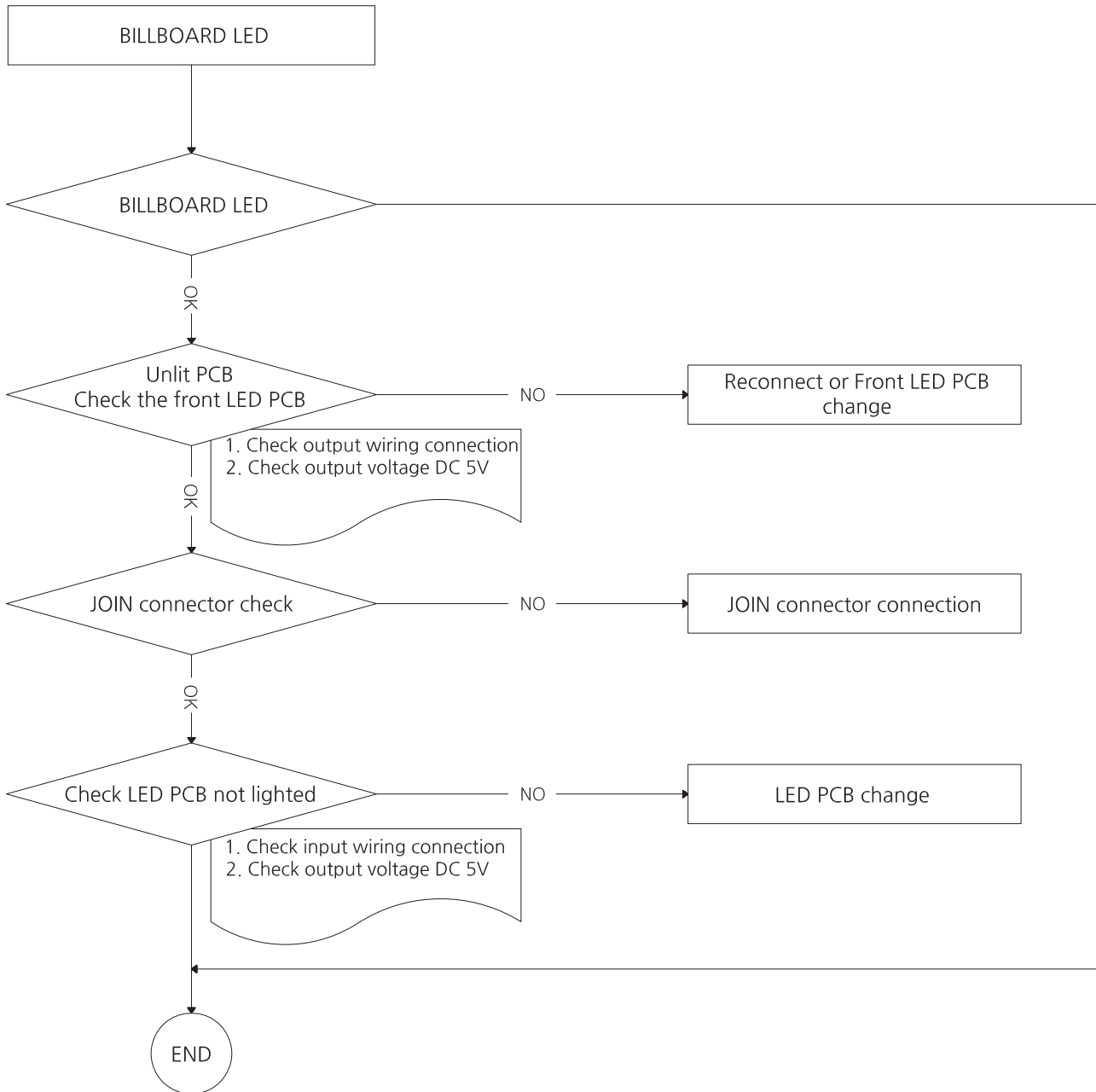

* LED DOT Only one color is wrong or not lit - Replace corresponding LED or replace LED PCB

6-14. BOTTOM LED PCB ERROR (all)

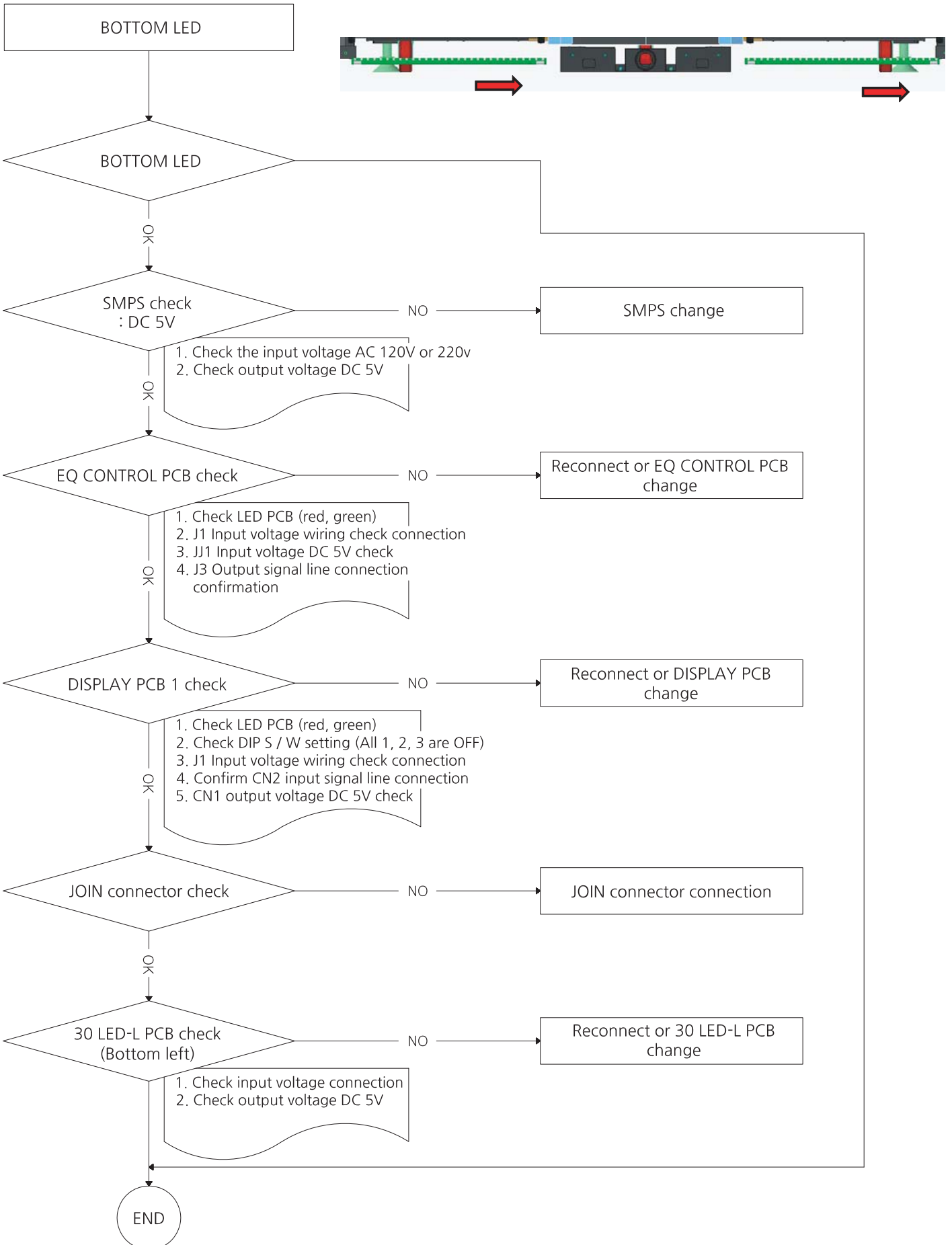

6-15. SIDE L LED ERROR (all)

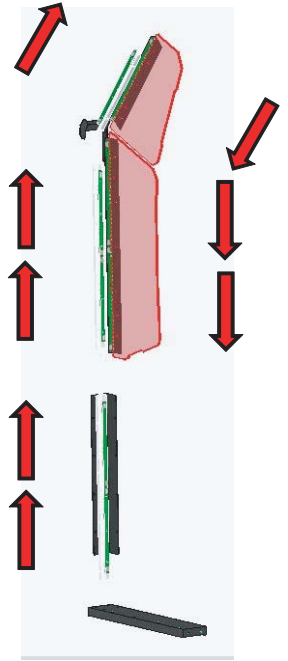
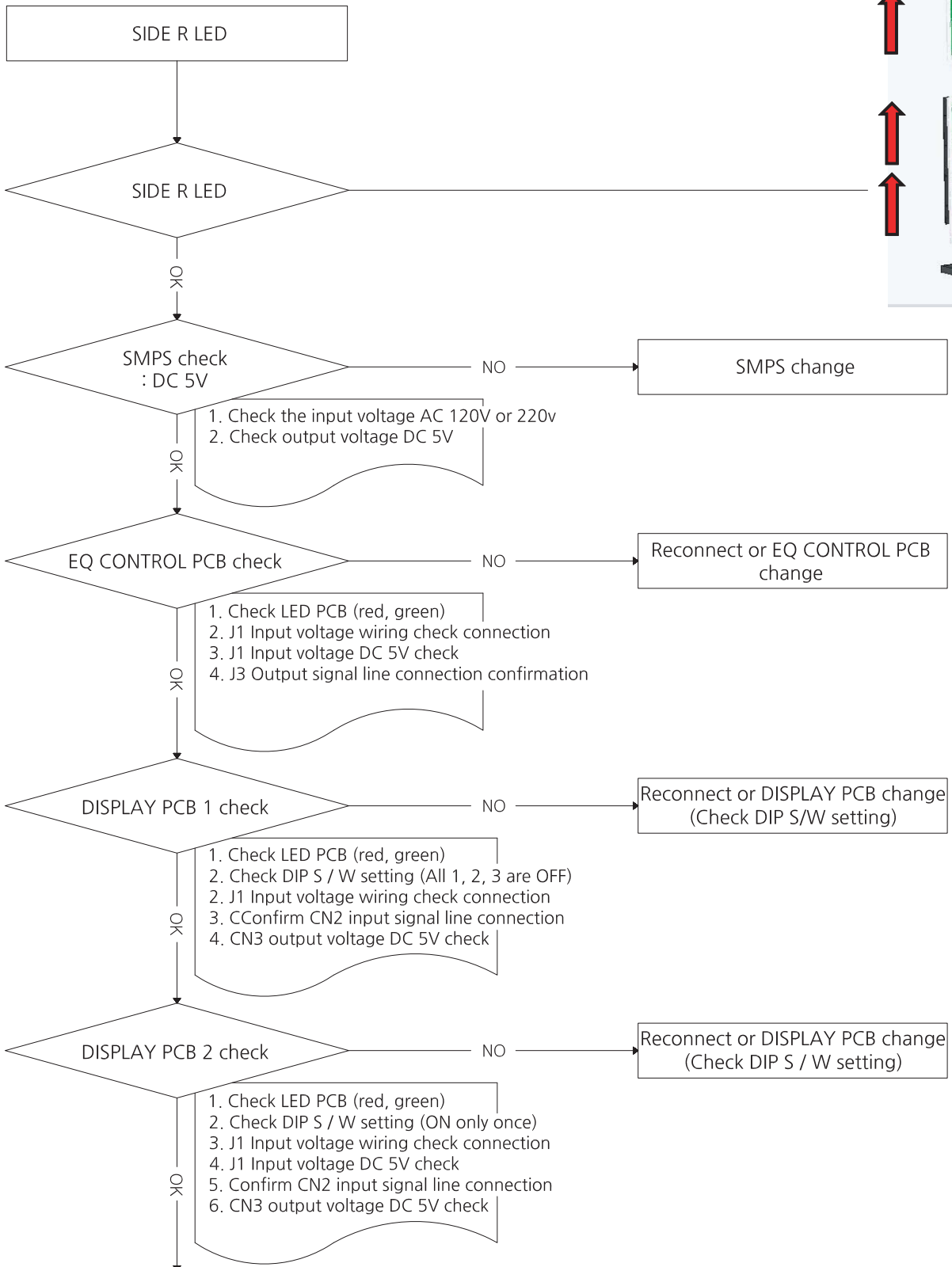

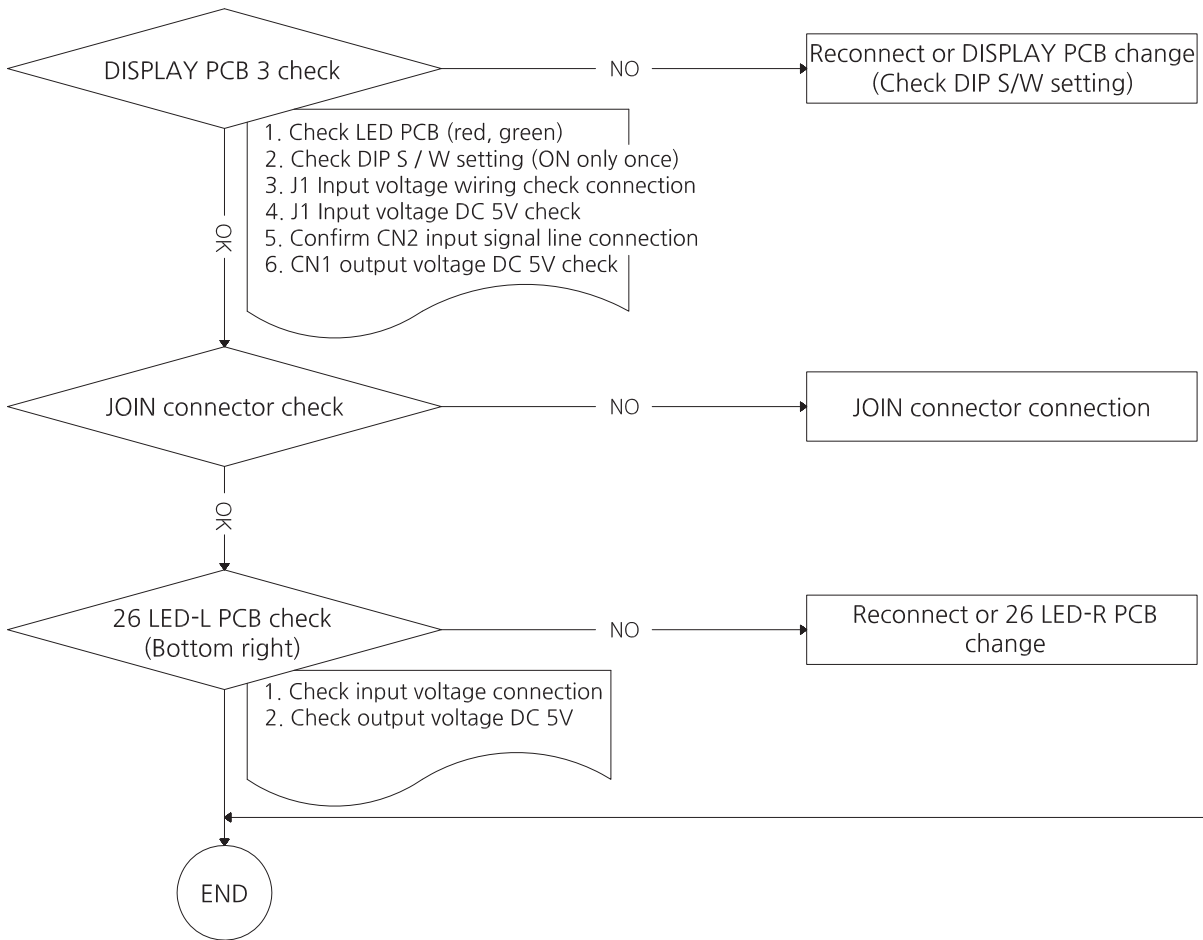

6-16. SIDE R LED ERROR (all)

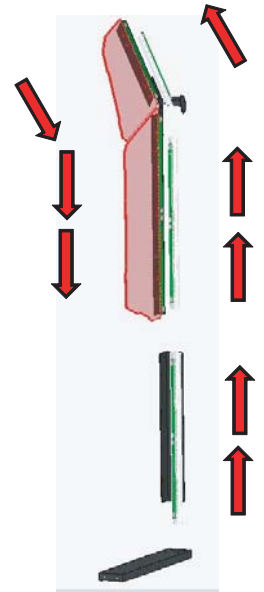
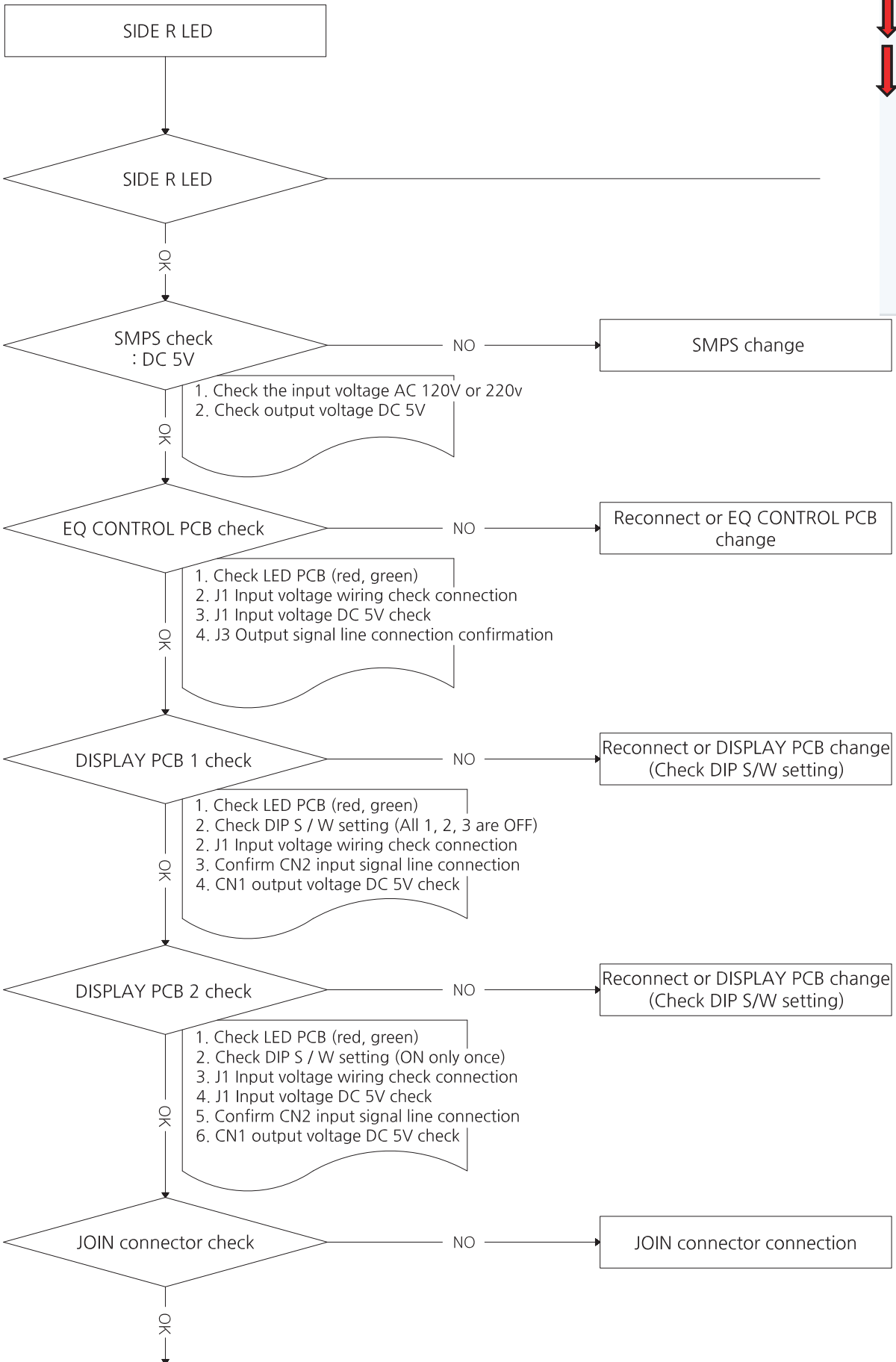

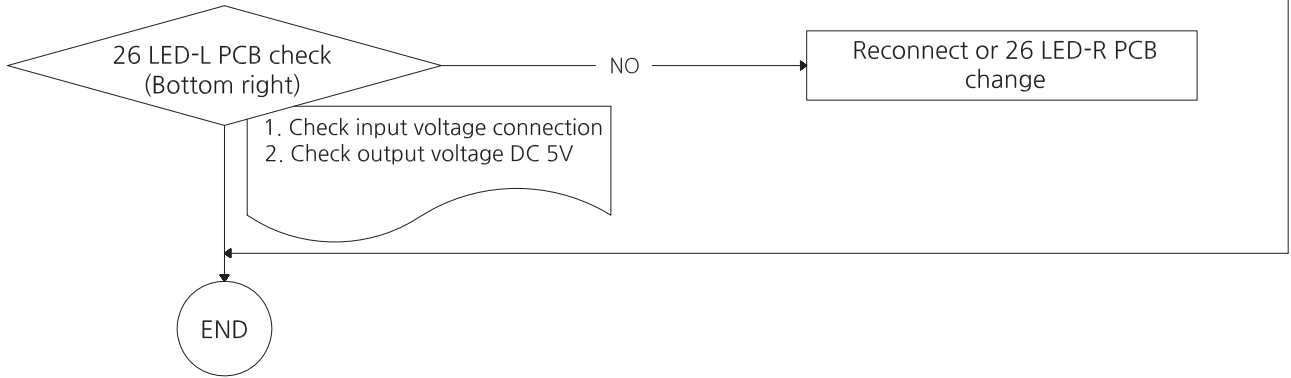

6-17. WOOFER BOX L LED ERROR (all)

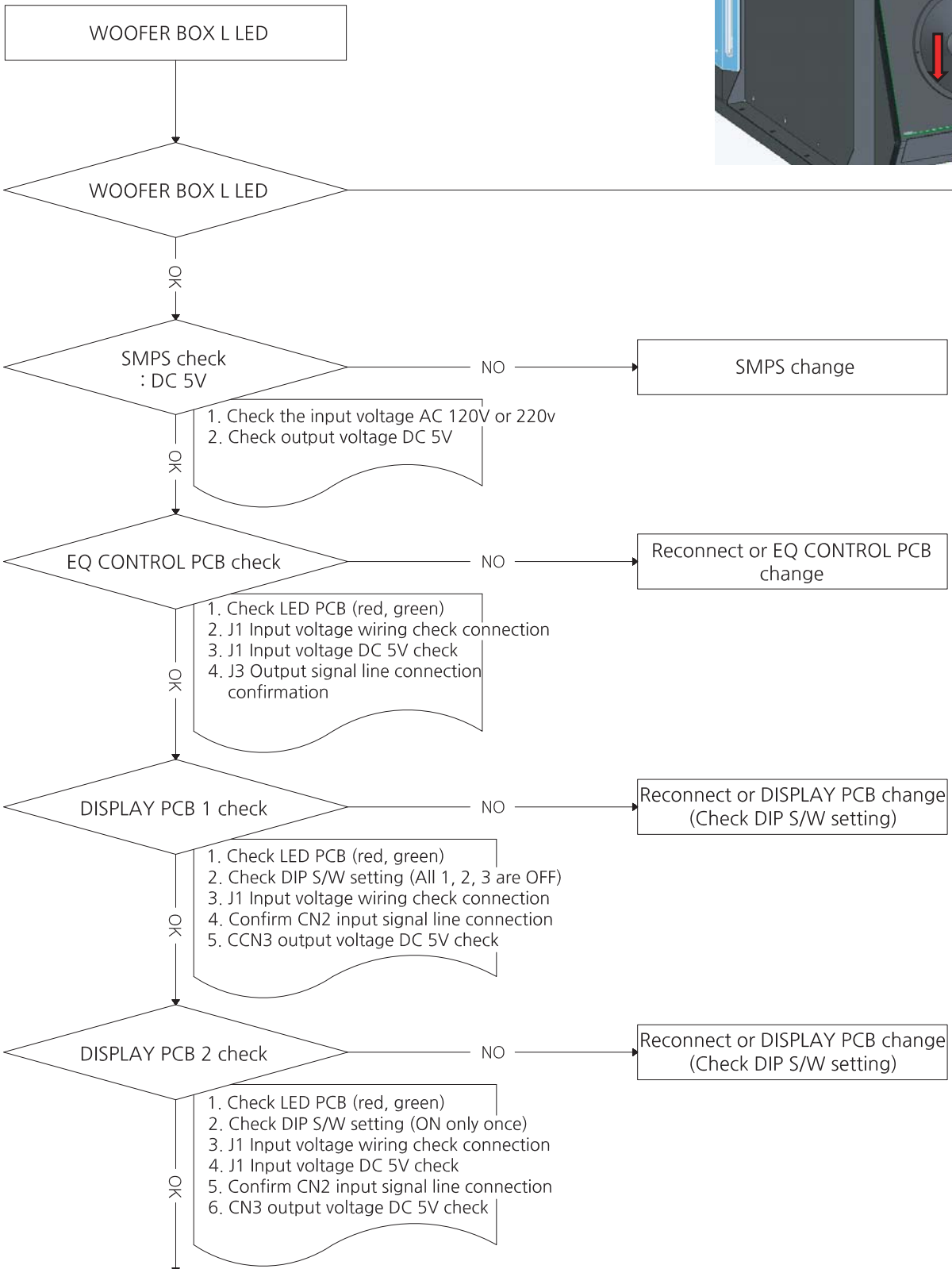
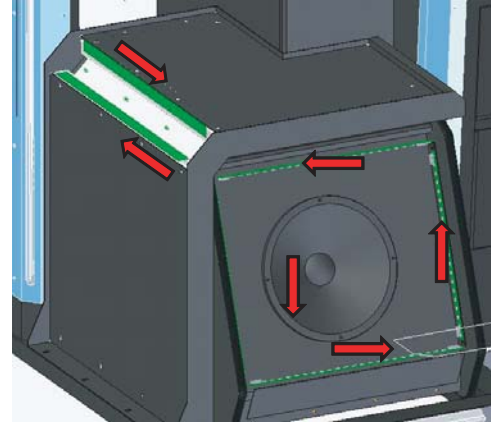

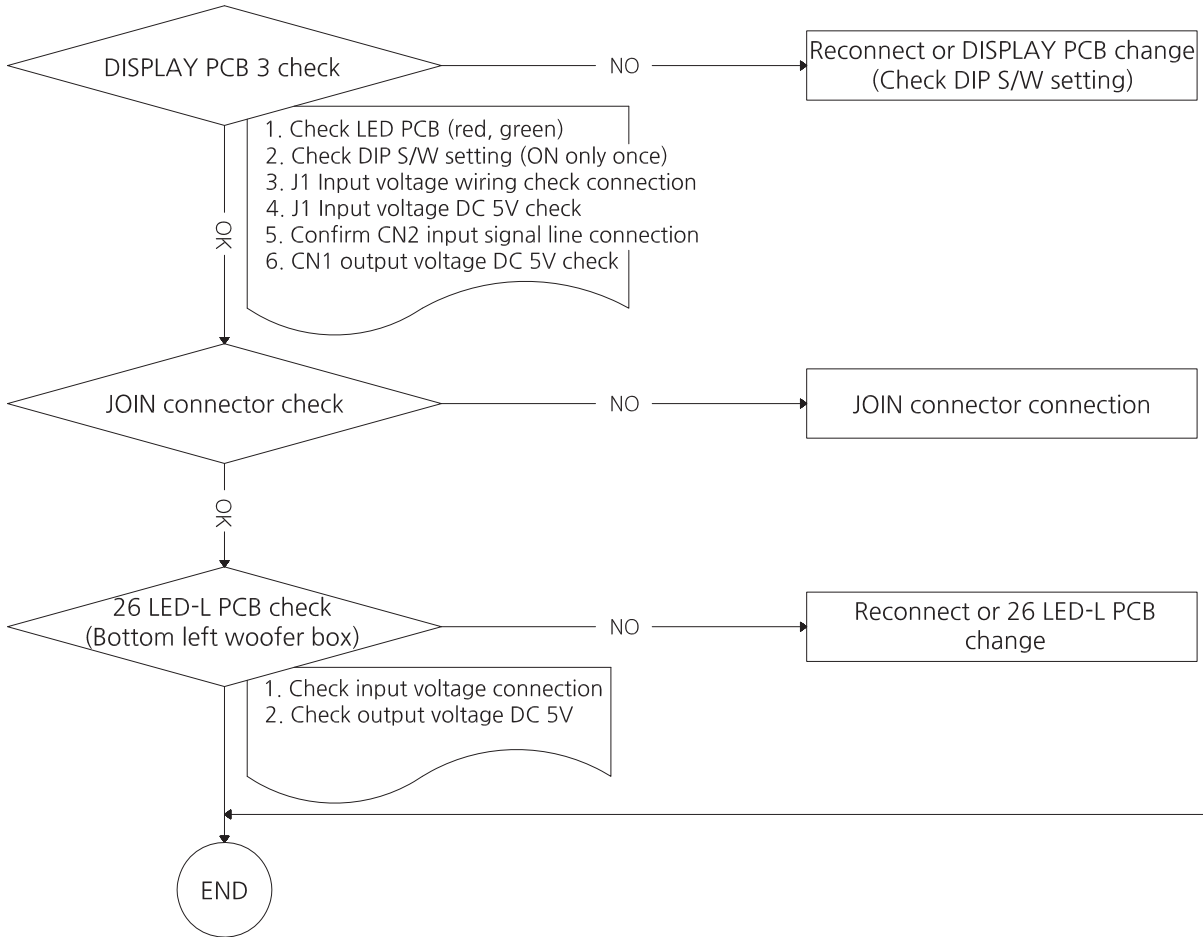

6-18. WOOFER BOX R LED ERROR (all)

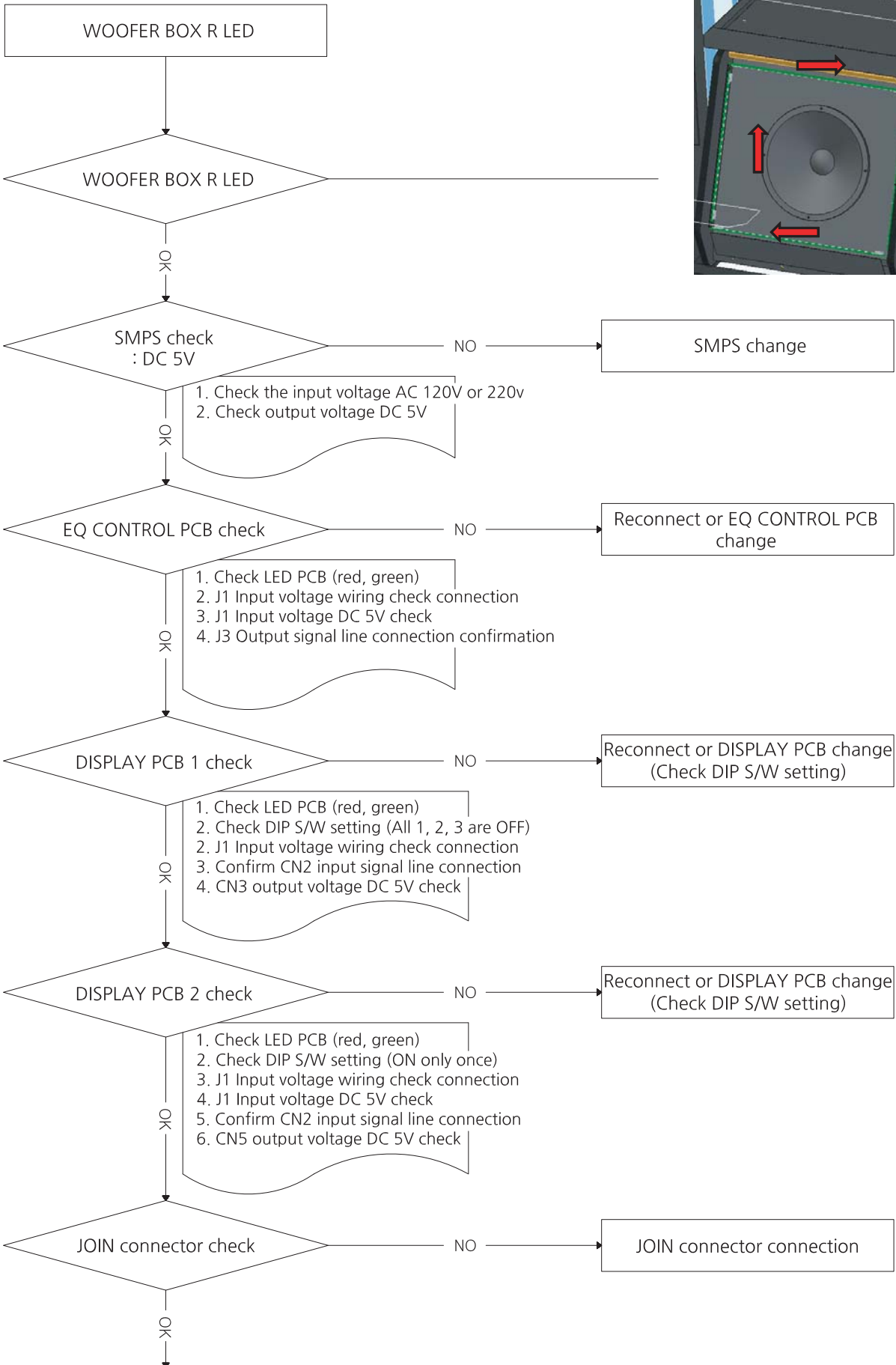
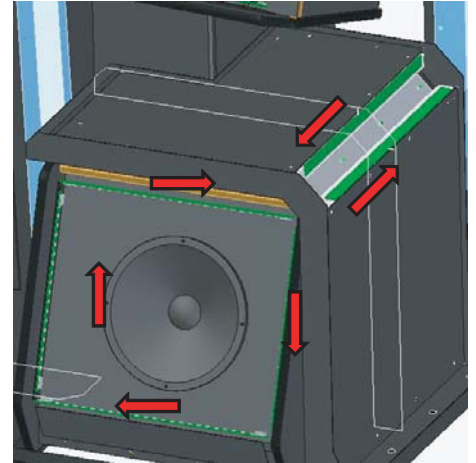

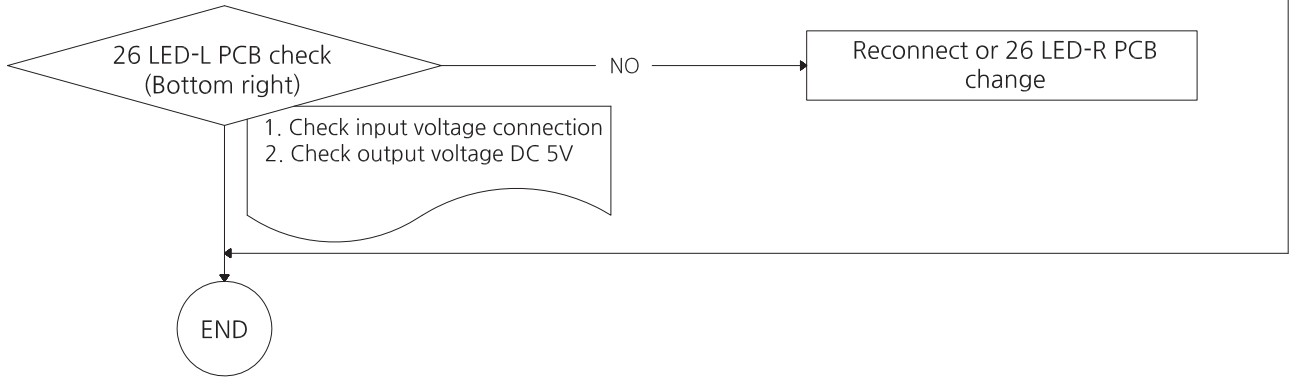

* COMMON_LED PCB ERROR (part)

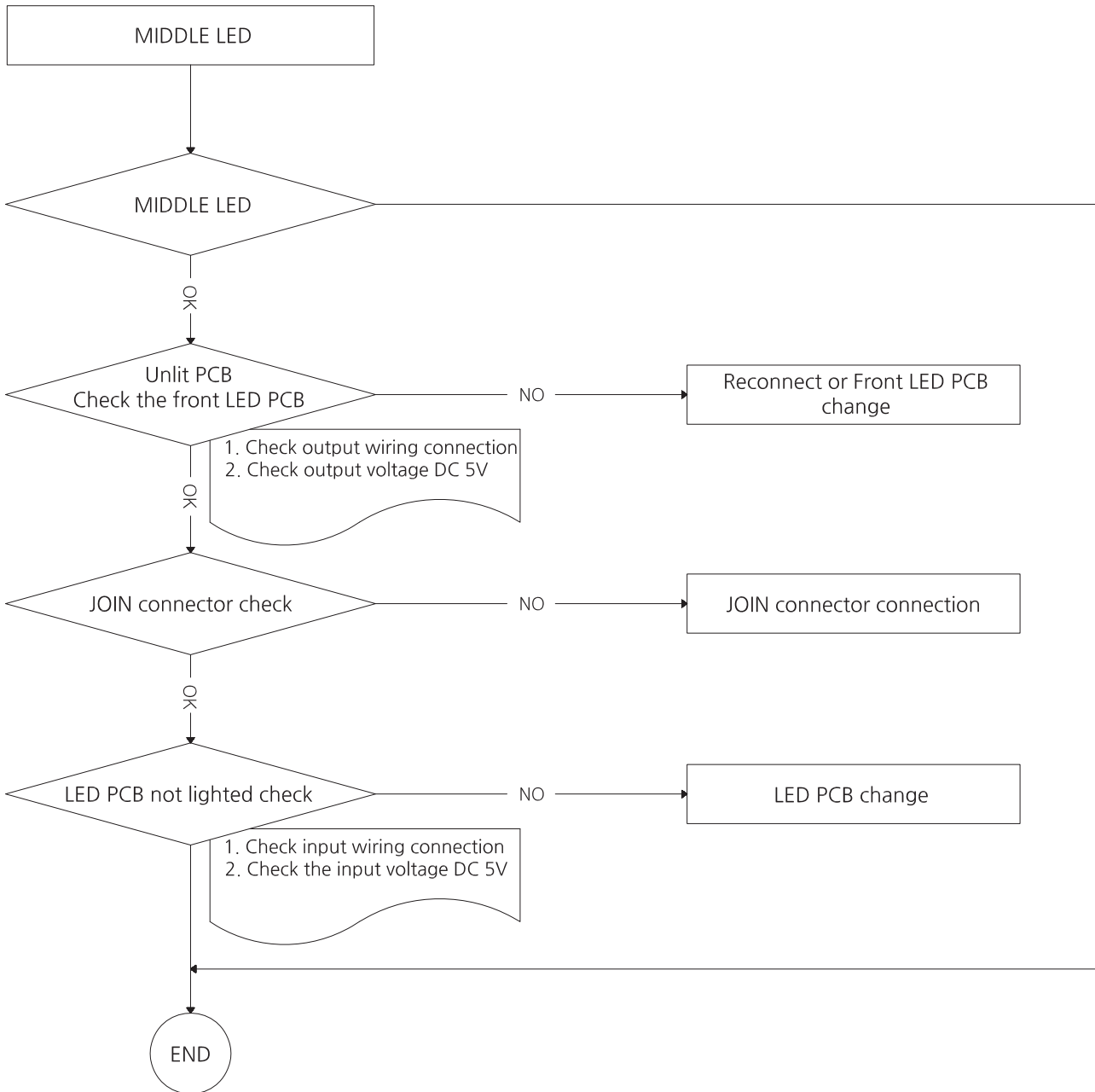

* LED DOT Only one color is wrong or not lit - Replace corresponding LED or replace LED PCB

* IF ALL THE COLOR LEDS ARE NOT LIGHT ON

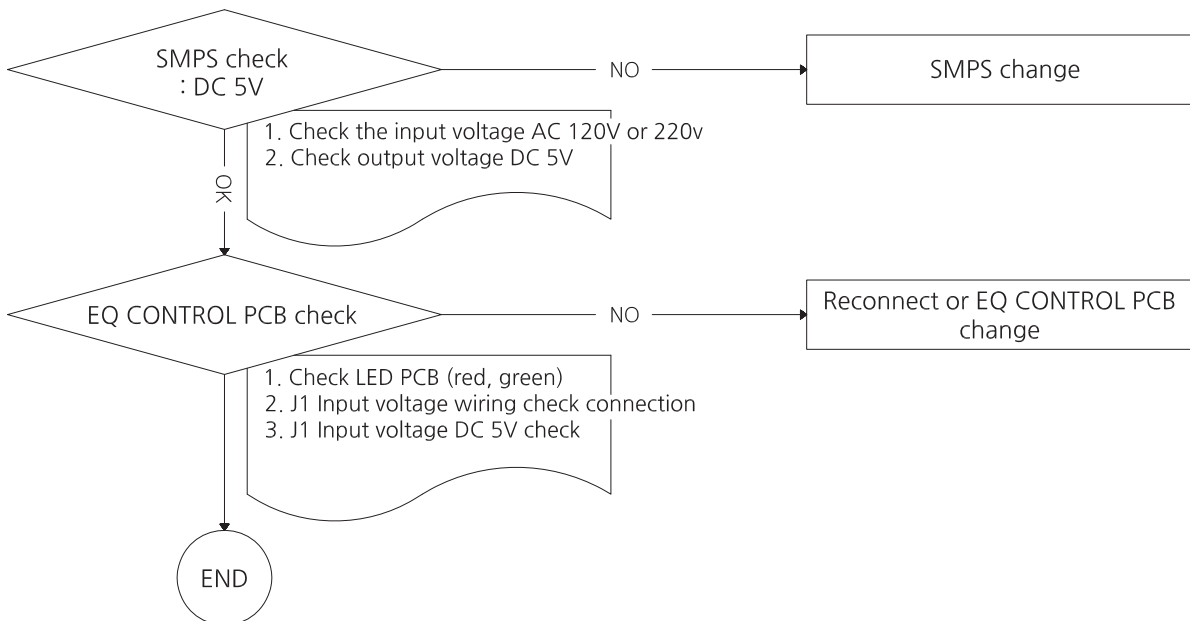

* WHEN THE COLOR LED IS LIT ONLY IN RED, GREEN, BLUE, AND WHITE

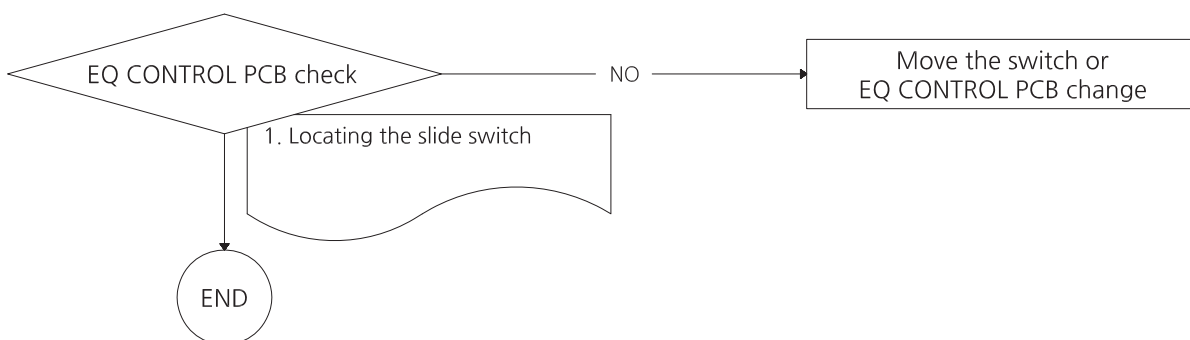

* WHEN THE COLOR LED IS ONLY LIT IN WHITE, BLUE, OR OFF

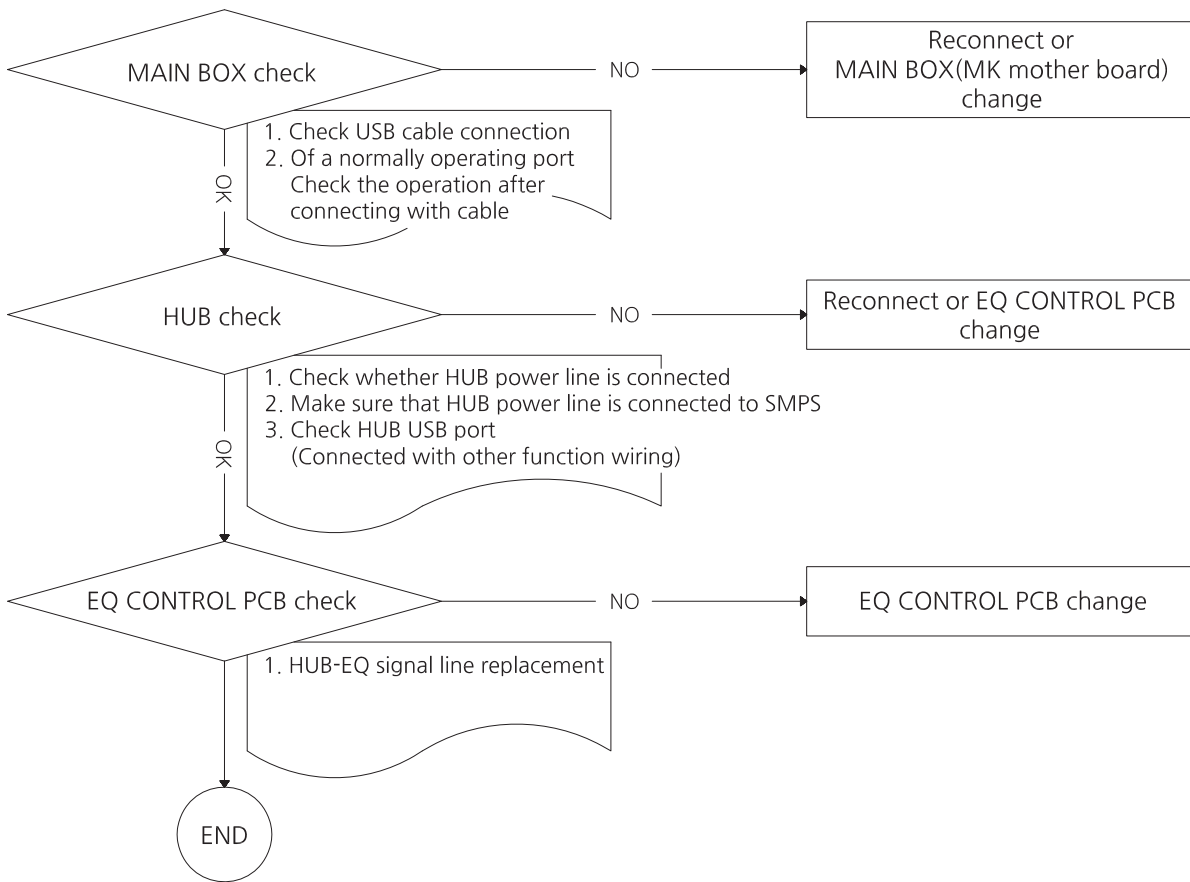

6-19. WHEN THE WHITE LIGHT AND THE BLUE LIGHT COME OUT ONLY OCCASIONALLY (EQ malfunction)

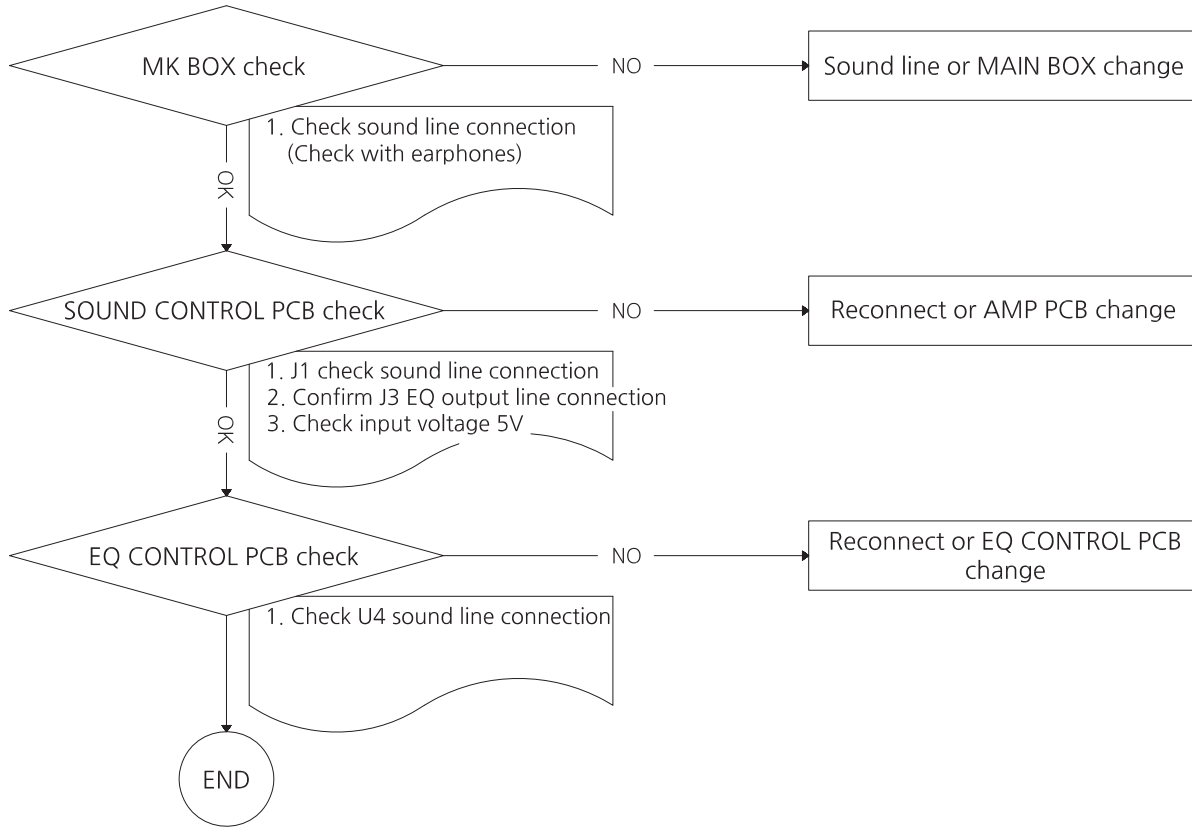

6-20. SOUND ERROR

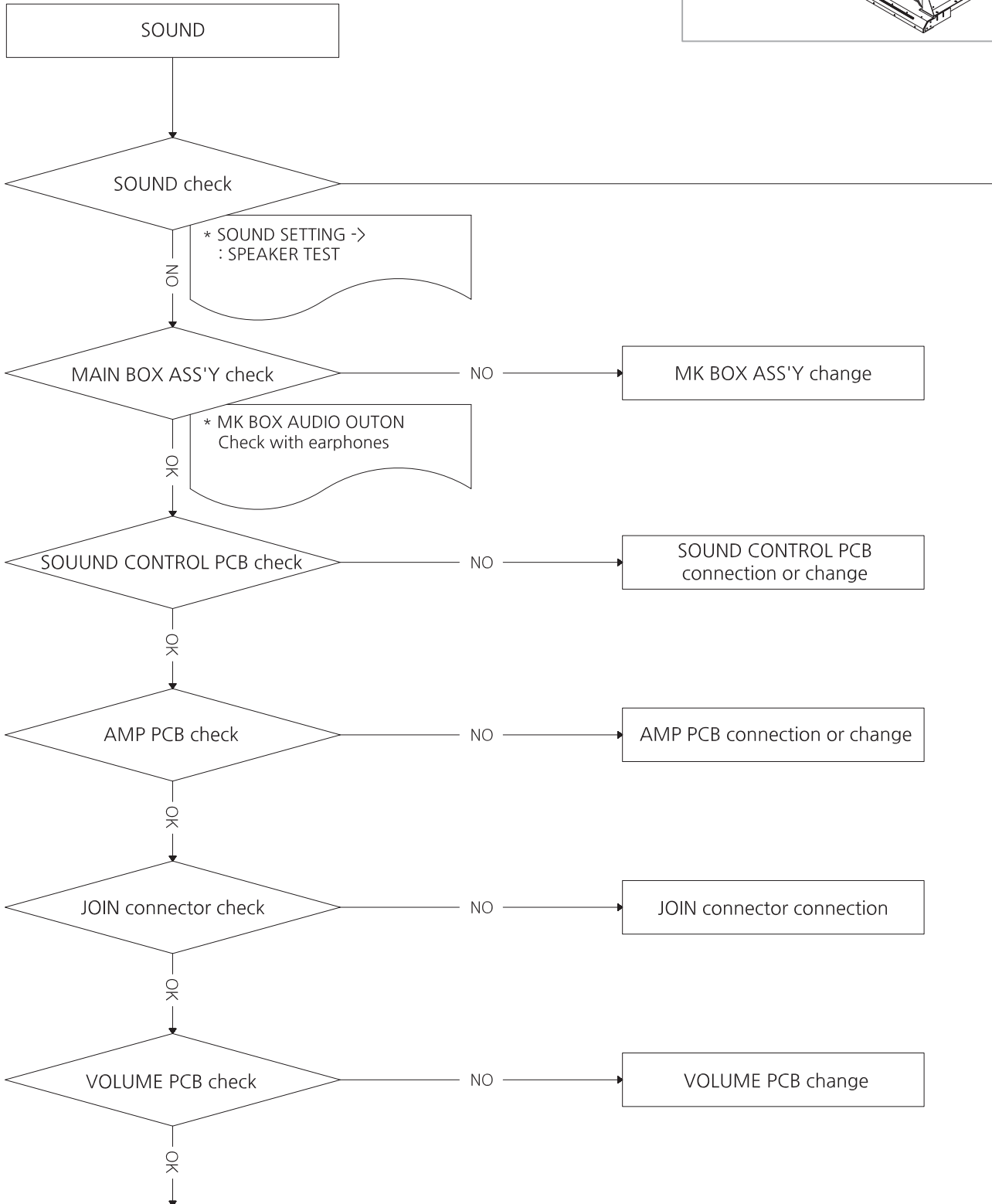
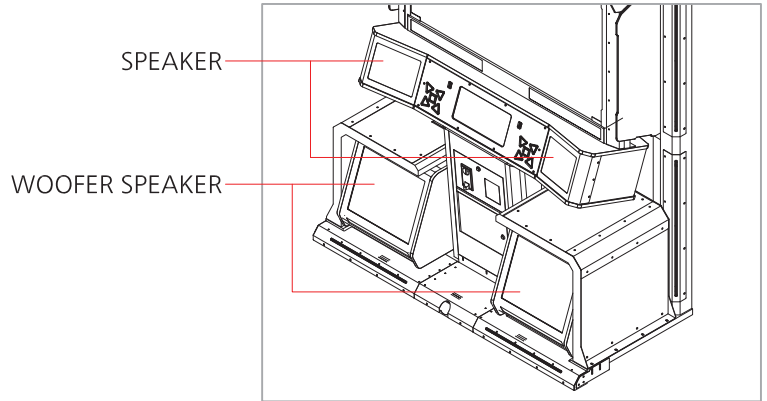

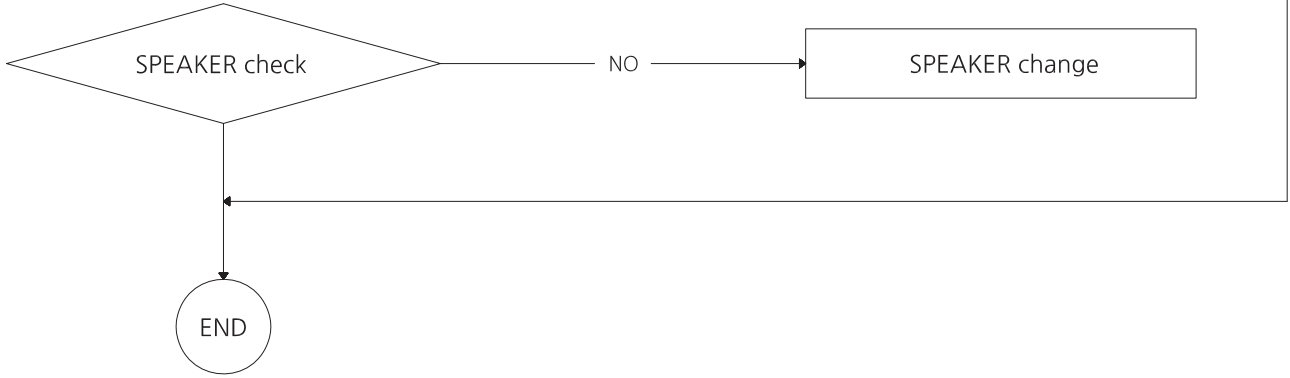

7. EXPLODED VIEW

7-1. MAIN CABINET PART

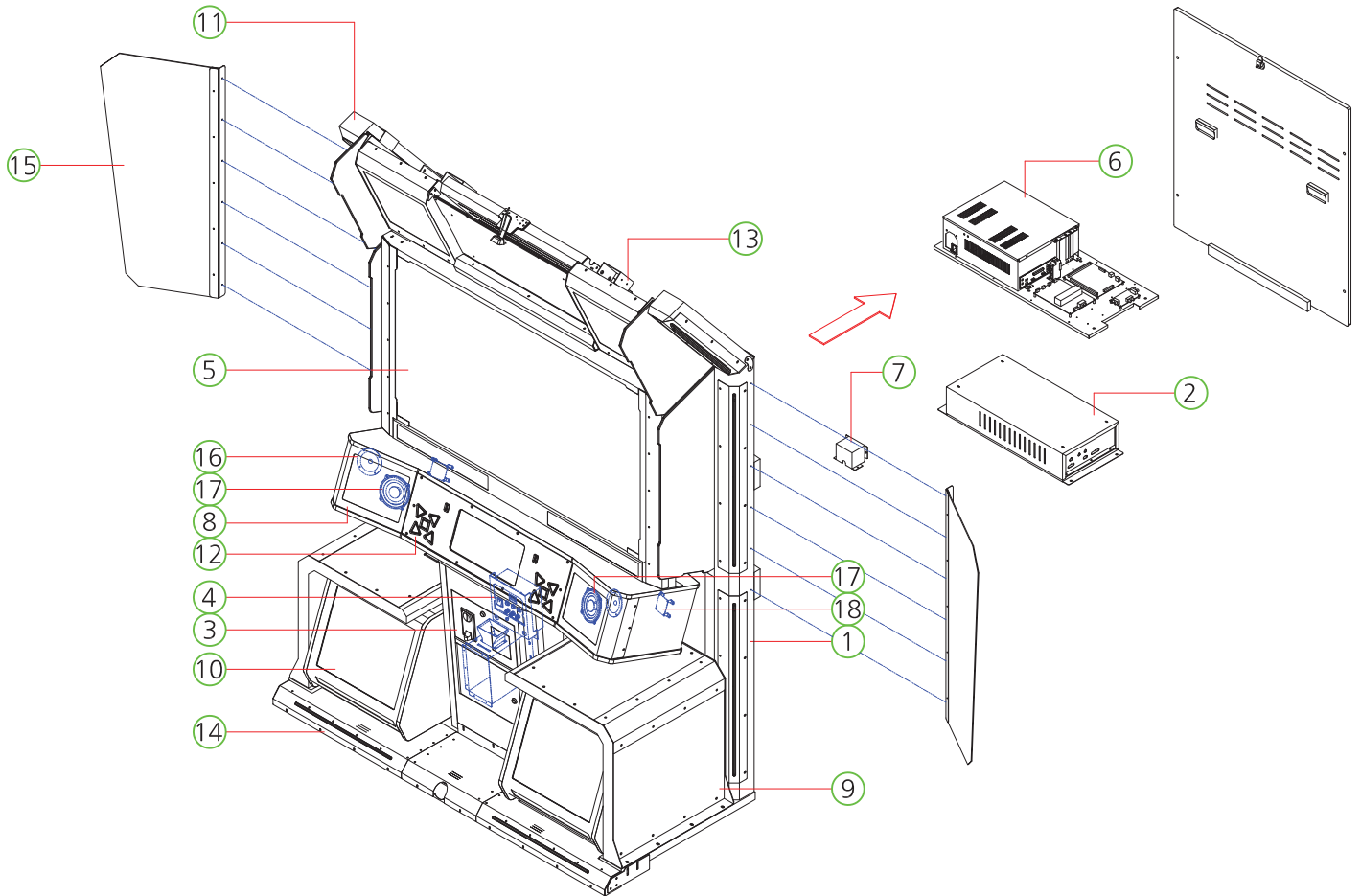

NO.	PART NAME	SPEC.	QUANTITY	CODE NO.
1	MAIN CABINET	-	1	-
2	POWER BASE PART	-	1	-
3	COIN DOOR CASE PART	-	1	-
4	SETUP PANEL PART	-	1	-
5	MONITOR PART	-	1	-
6	PC BASE PART	-	1	-
7	AC INPUT PART	-	1	-
8	MID SPEAKER SIDE COVER L,R PART	-	2	-
9	SPEAKER DECO PART	-	2	-
10	WOOFER SPEAKER COVER L,R PART	-	2	-
11	LIGHT COLUME L,R PART	-	2	-
12	MID SPEAKER FRONT COVER PART	-	2	-
13	BILLBOARD PART	-	1	-
14	BASE LIGHT DECO PART	-	1	-
15	[OPTION] POP PART	-	1	-
16	SPEAKER	-	2	MZZZOSPE026
17	SPEAKER	5.25"	2	MZZZOSPE027
18	SPEAKER NETWORK PCB ASS'Y	-	2	APUTOPCB007

7-2. POWER BASE PART

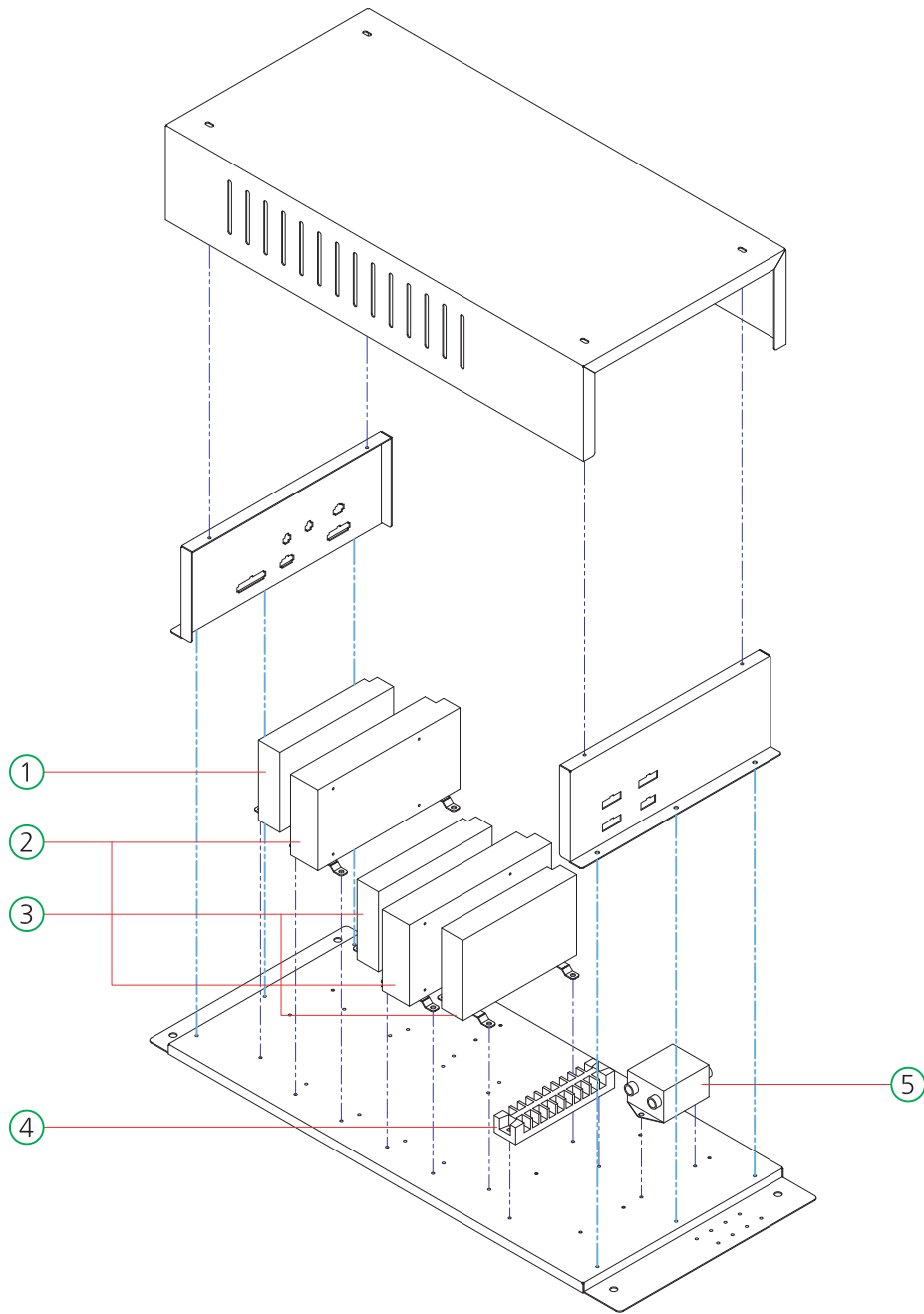

NO.	PART NAME	SPEC.	QUANTITY	CODE NO.
1	POWER SMPS	LRS-150F-5V	1	MELE0SMP096
2	POWER SMPS	NES-150-24V	2	MELE0SMP049
3	POWER SMPS	LRS-150F-12V	2	MELE0SMP090
4	TERMINAL BLOCK	250V, 10P	1	MELE0TEB003
5	NOISE FILTER	ES1-F10	1	MELE0NOI006

7-3. COIN DOOR CASE PART

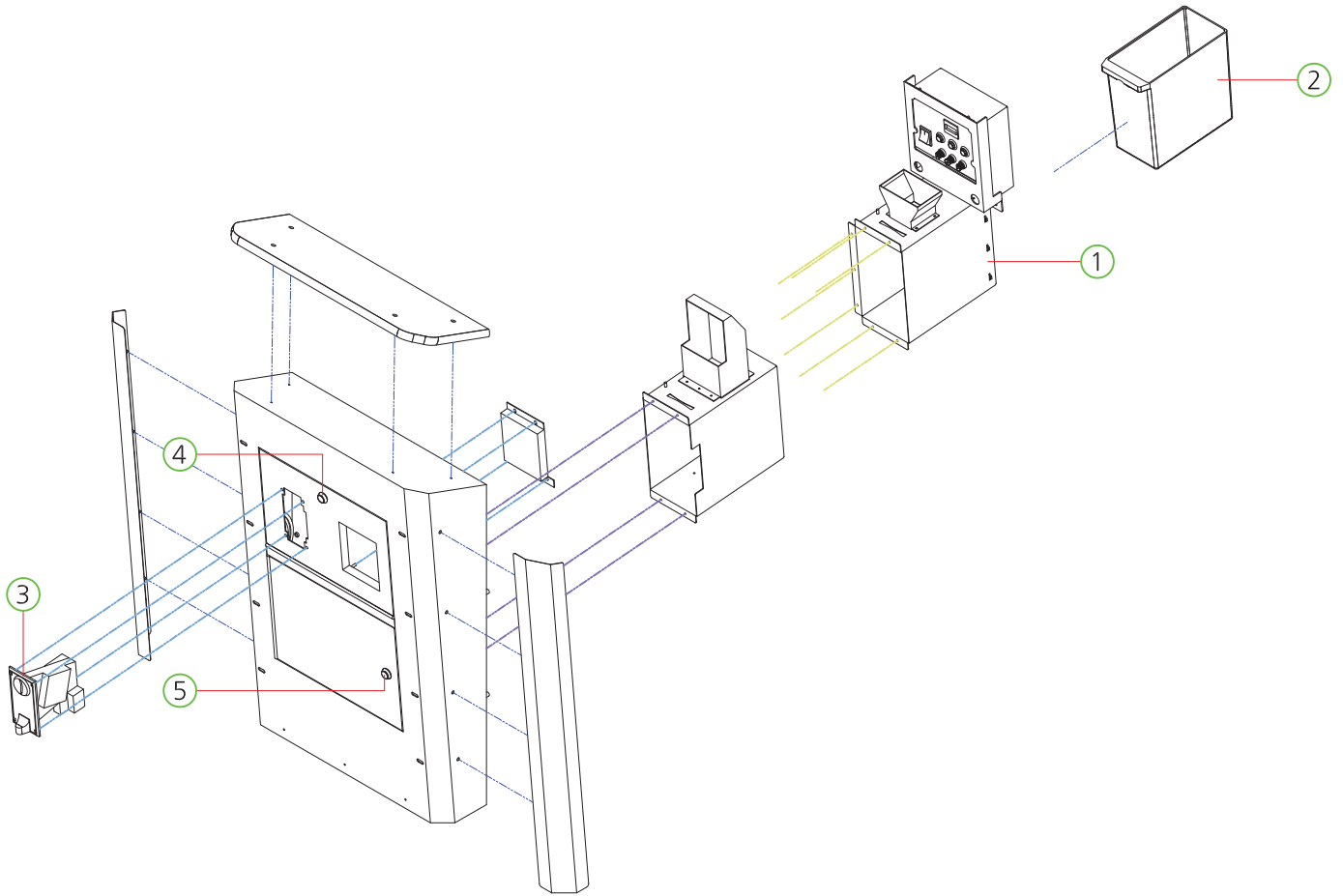

NO.	PART NAME	SPEC.	QUANTITY	CODE NO.
1	SETUP PANEL ASS'Y	-	1	-
2	COIN BOX	-	1	MDRE0PLA007
3	COIN SELECTOR	TW-333	1	MZZZ0COS045
4	KEY ASS'Y	7001	1	MZZZ0KEY076
5	KEY ASS'Y	6001	1	MZZZ0KEY075

7-4. SETUP PANEL PART

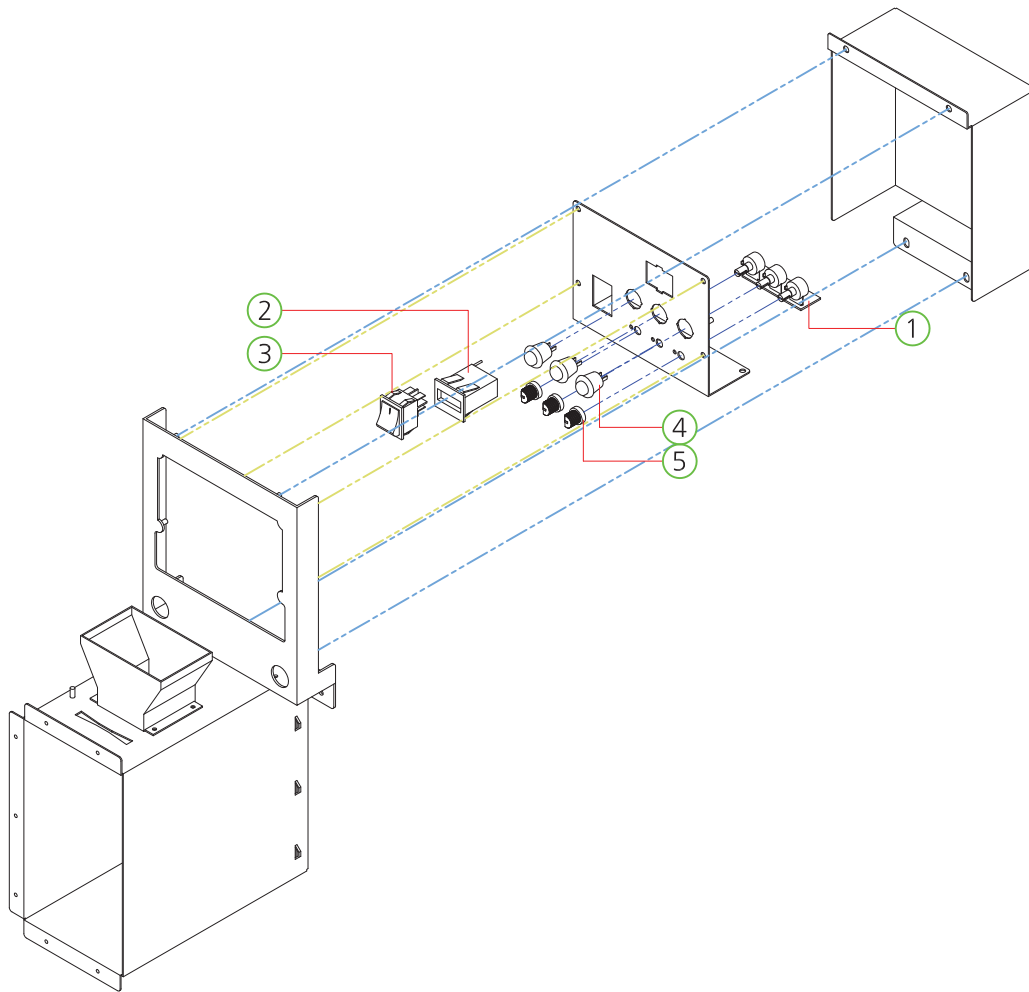

NO.	PART NAME	SPEC.	QUANTITY	CODE NO.
1	VOLUME PCB ASS'Y	3CH	1	APUJ0PCB005
2	COUNTER	712	1	MZZZ0COU002
3	ROCKER SWITCH	T-125, 4P	1	MELE0SWI004
4	PUSH BUTTON SWITCH	HS_412R	3	MELE0PUS001
5	VOLUME KONB	-	3	MELE0VOL007

7-5. MONITOR PART

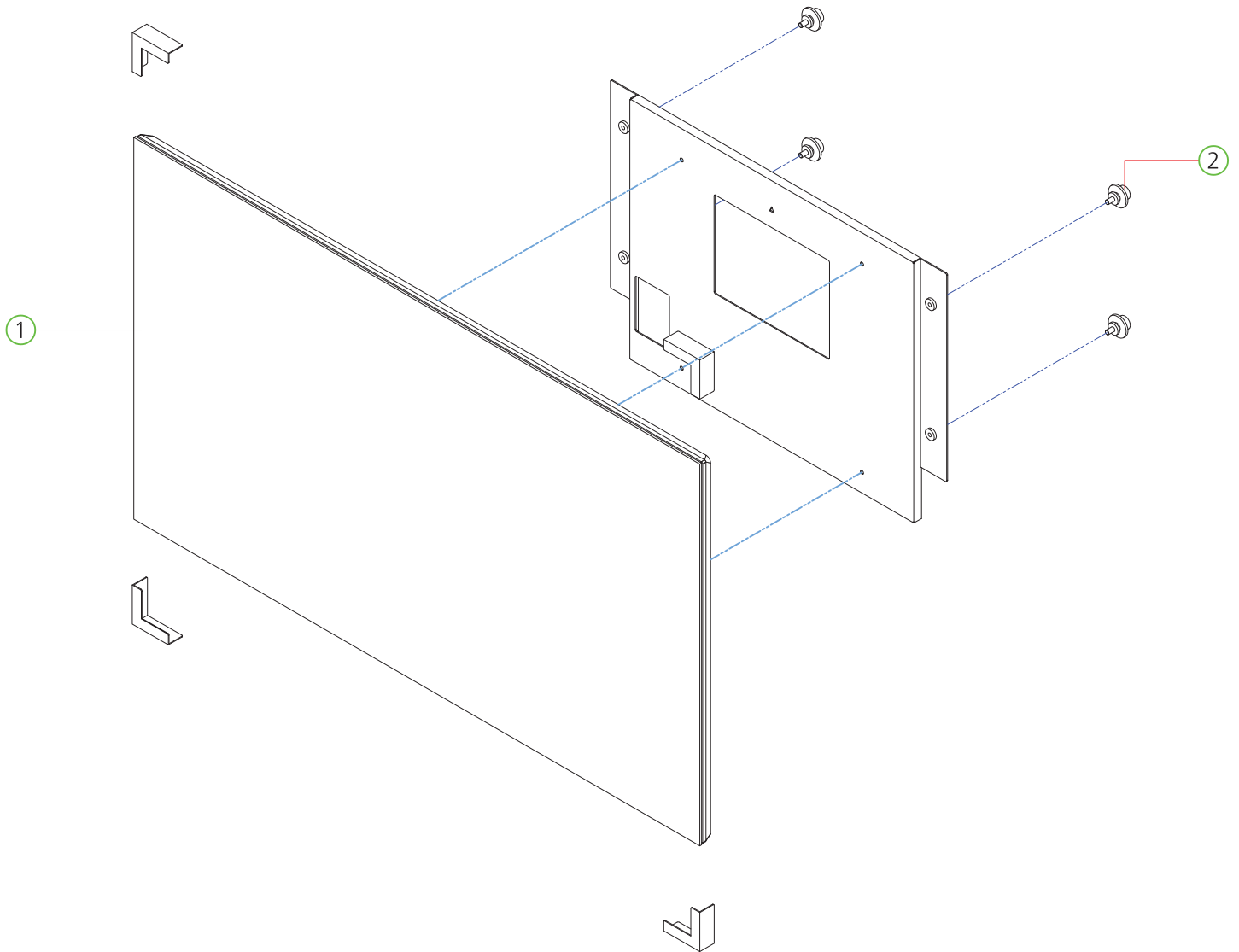

NO.	PART NAME	SPEC.	QUANTITY	CODE NO.
1	LED MONITOR	55"	1	MZZZ0MON032
2	WALL MOUNT BLOCK	-	4	MPUJ0ZZZ003

7-6. PC BASE PART

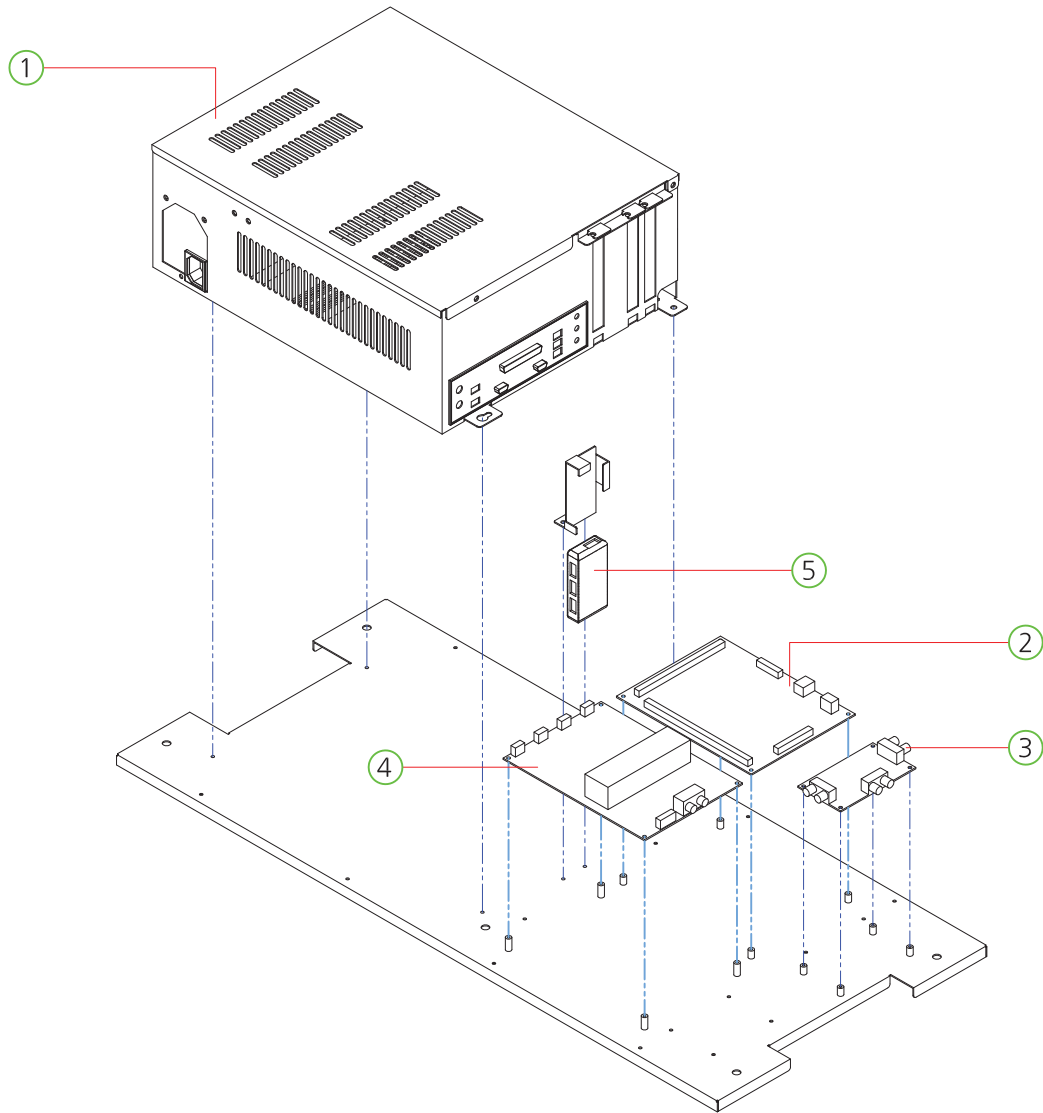

NO.	PART NAME	SPEC.	QUANTITY	CODE NO.
1	MAIN BOX ASS'Y	-	1	-
2	PIU IO PCB ASS'Y	-	1	AZZZ0PCB145
3	DSP SOUND DVI PCB ASS'Y	-	1	APLX0PCB012
4	DIGITAL AMP 100W PCB ASS'Y	-	1	APLX0PCB011
5	USB HUB	-	1	MZZZ0000602

7-7. PCB BASE PART

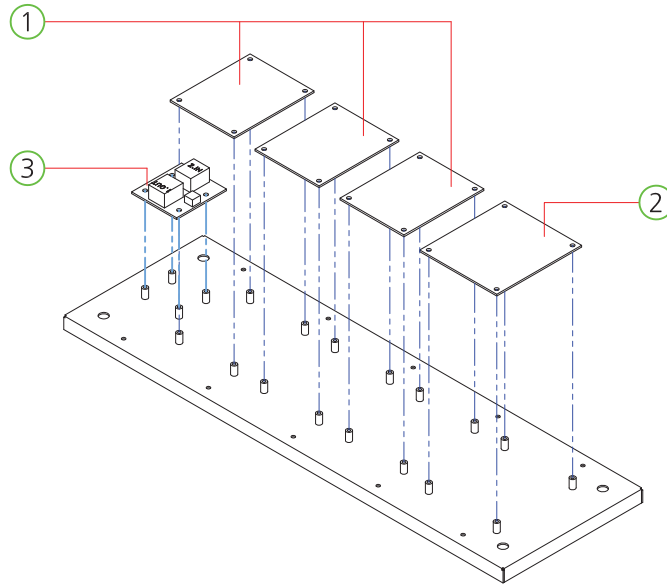

NO.	PART NAME	SPEC.	QUANTITY	CODE NO.
1	WS2813B DISPLAY PCB ASS'Y	-	3	APLX0PCB002
2	EQ CONTROL PCB ASS'Y	-	1	APLX0PCB001
3	LAN JOIN PCB ASS'Y	-	1	AZZZ0PCB096

7-8. AC INPUT PART

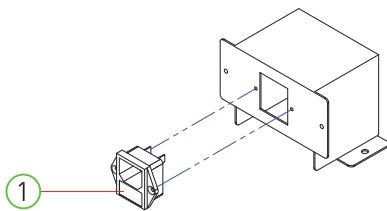

NO.	PART NAME	SPEC.	QUANTITY	CODE NO.
1	AC INPUT	DAC-13H	1	MELE0SWI015
2	FUSE	250V, 10A	2	MELE0FUS018

7-9. LAN CABLE PART

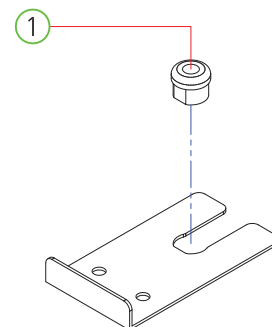

NO.	PART NAME	SPEC.	QUANTITY	CODE NO.
1	CABLE STOPPER	5NR-16	1	MELE0CAB026

7-10. MID SPEAKER SIDE COVER L,R PART

L

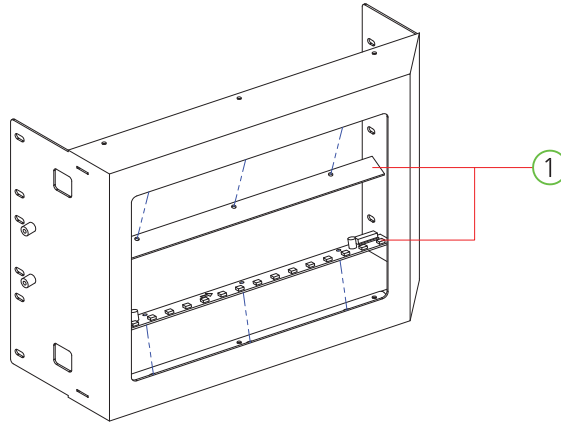

R

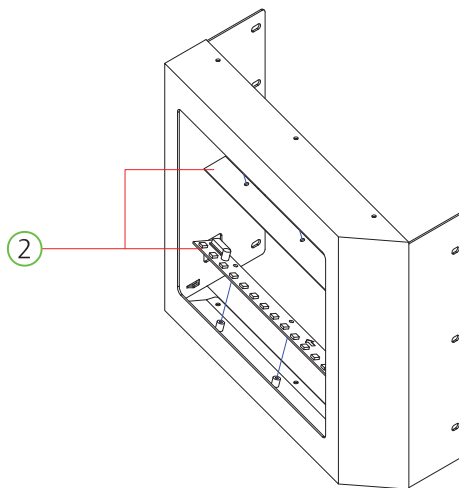

NO.	PART NAME	SPEC.	QUANTITY	CODE NO.
1	16EA- L LED PCB ASS'Y	-	2	APLX0PCB007
2	16EA- R LED PCB ASS'Y	-	2	APLX0PCB003

7-11. SPEAKER DECO PART

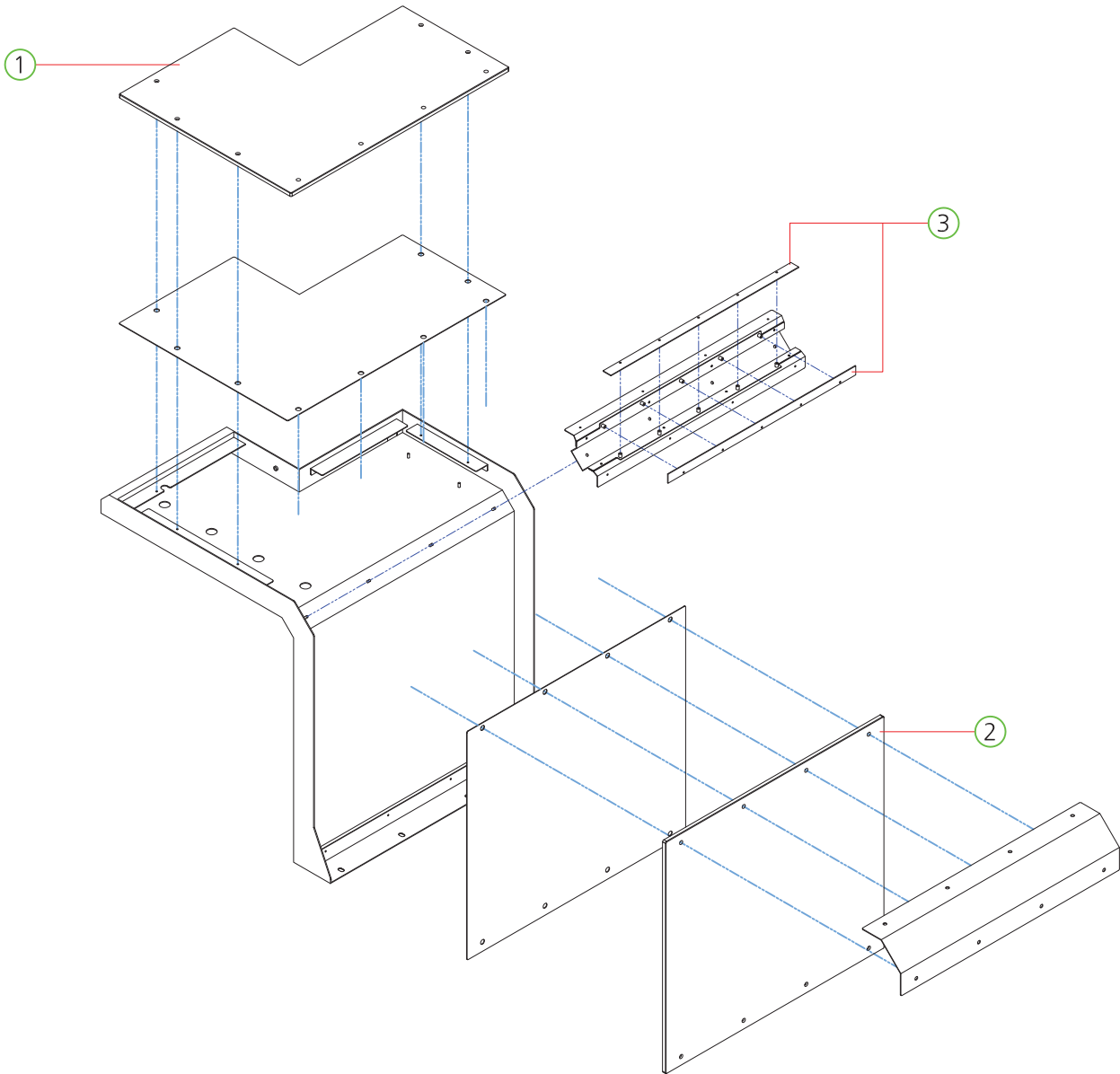

NO.	PART NAME	SPEC.	QUANTITY	CODE NO.
1	SPEAKER DECO TOP ACRYL-R	ACRYL-8.0t	1	MPLX0ACR015
2	SPEAKER DECO TOP ACRYL-R	ACRYL-8.0t	1	MPLX0ACR014
3	30EA-L LED PCB ASS'Y	-	2	MPLX0PCB006
	30EA-R LED PCB ASS'Y	-	2	MPLX0PCB010

7-12. WOOFER SPEAKER COVER L,R PART

L

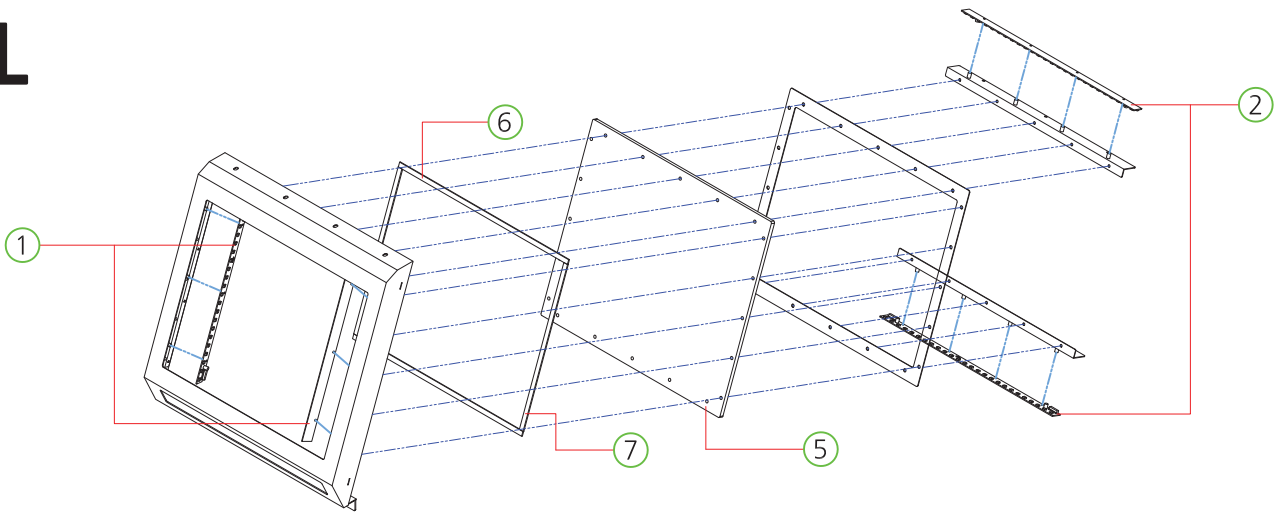

R

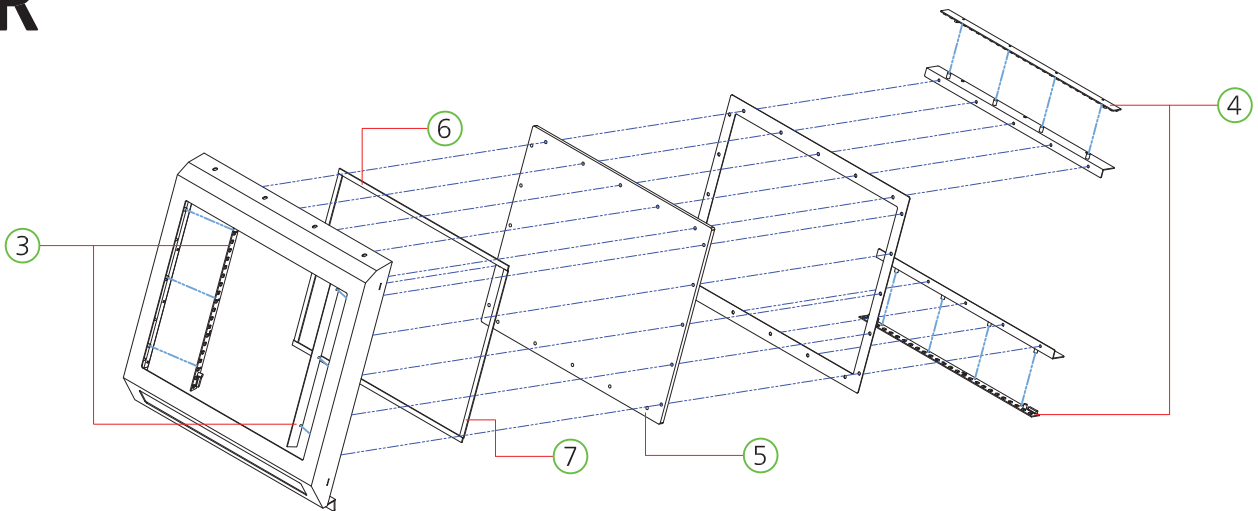

NO.	PART NAME	SPEC.	QUANTITY	CODE NO.
1	21EA_L LED PCB ASS'Y	-	2	APLX0PCB004
2	26EA_R LED PCB ASS'Y	-	2	APLX0PCB005
3	21EA_R LED PCB ASS'Y	-	2	APLX0PCB008
4	26EA_R LED PCB ASS'Y	-	2	APLX0PCB009
5	WOOFER SPEAKER ACRYL	ACRYL-8.0t	2	APLX0ACR024
6	SPONGE TOP	-	2	-
7	SPONGE SIDE	-	2	-

7-13. LIGHT COLUME L PART

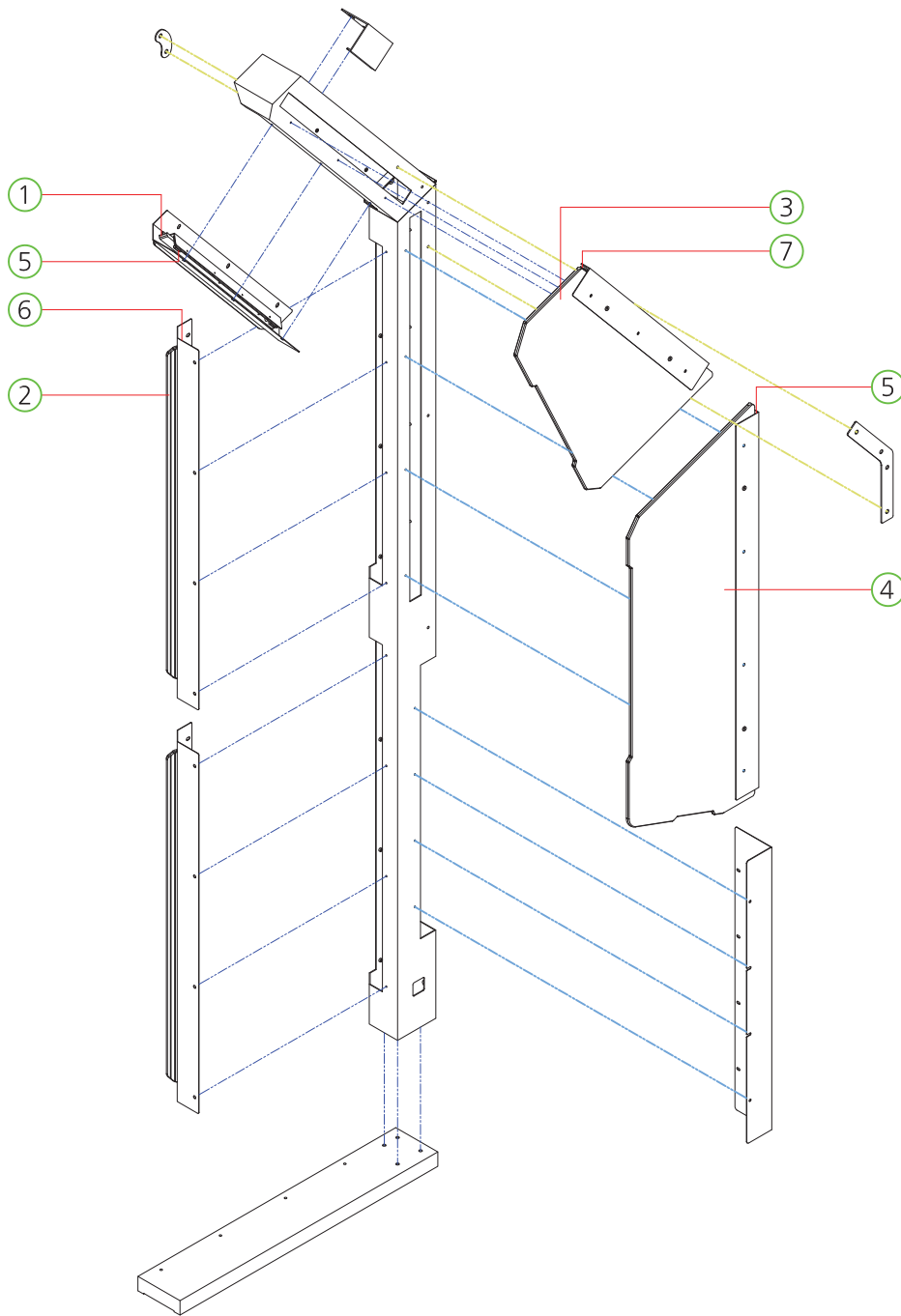

NO.	PART NAME	SPEC.	QUANTITY	CODE NO.
1	LIGHT COLUMN SMALL COVER ACRYL	ACRYL-8.0t	1	MPLX0ACR011
2	LIGHT COLUMN LARGE COVER ACRYL	ACRYL-8.0t	1	MPLX0ACR009
3	LIGHT COLUMN SMALL ACRYL-L	ACRYL-8.0t	1	MPLX0ACR020
4	LIGHT COLUMN LARGE ACRYL-L	ACRYL-8.0t	1	MPLX0ACR019
5	30EA_L LED PCB ASS'Y	-	1	MPLX0PCB006
6	21EA_L LED PCB ASS'Y	-	4	MPLX0PCB004
7	26EA_L LED PCB ASS'Y	-	3	MPLX0PCB005
	30EA_R LED PCB ASS'Y	-	1	MPLX0PCB010
	21EA_R LED PCB ASS'Y	-	4	MPLX0PCB008
	26EA_R LED PCB ASS'Y	-	3	MPLX0PCB009

7-14. MID SPEAKER FRONT COVER PART

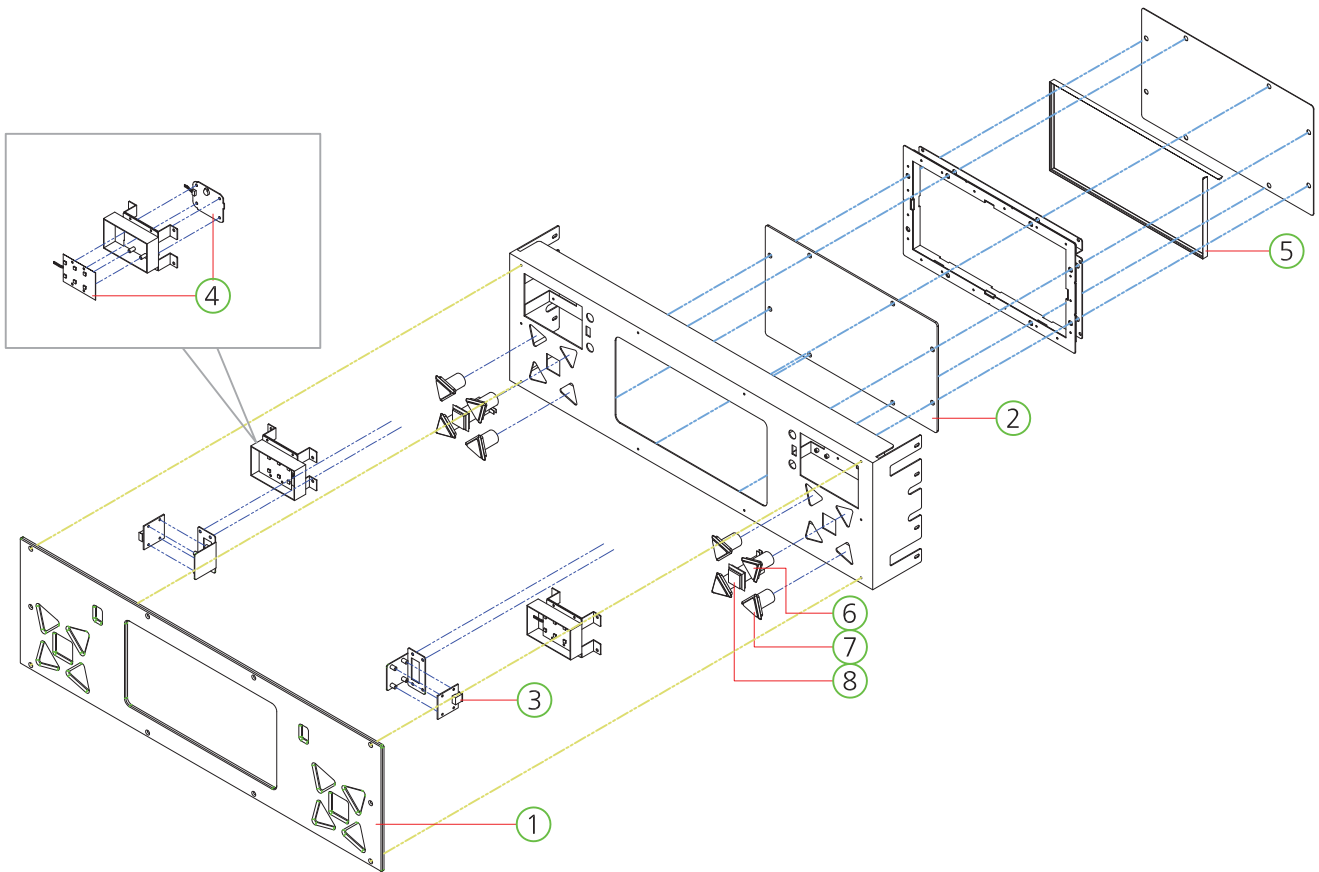

NO.	PART NAME	SPEC.	QUANTITY	CODE NO.
1	MID SPEAKER FRONT COVER ACRYL	ACRYL-5.0t	1	MPLX0ACR012
2	I.MIRROR BLACK MIRROR ACRYL	ACRYL-3.0t	1	MPLX0ACR007
3	USB ON/OFF PCB ASS'Y	-	2	APUF0PCB011
4	CARD READER PCB ASS'Y	-	2	MZZZ0PCB063
5	FLEX LED PCB ASS'Y	-	1	MPLX0HAN093
6	BUTTON SWITCH ASS'Y	RED	2	MZZZ0BUT116
7	BUTTON SWITCH ASS'Y	YELLOW	1	MZZZ0BUT118
8	BUTTON SWITCH ASS'Y	BLUE	2	MZZZ0BUT117

7-15. BILLBOARD PART

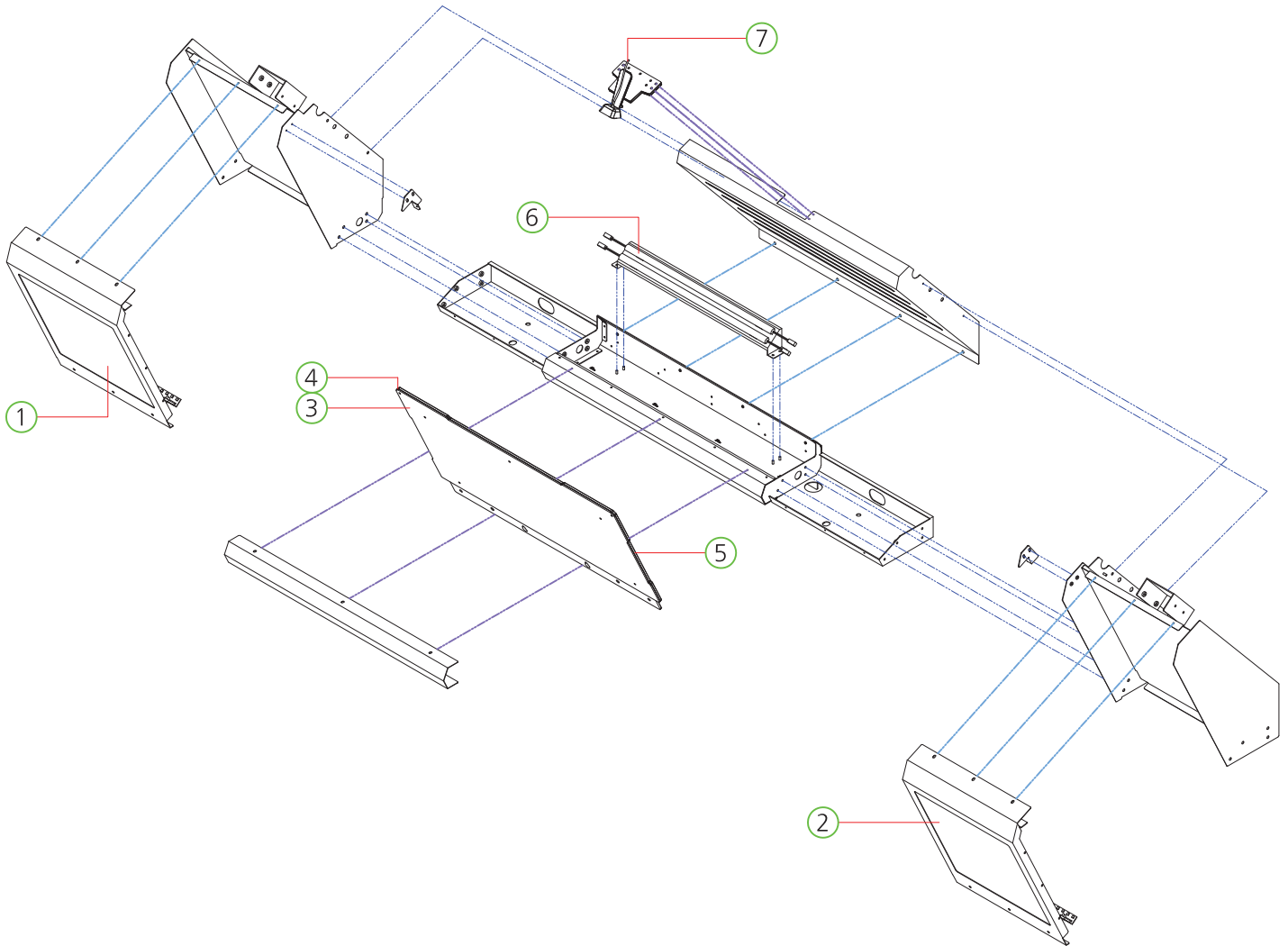

NO.	PART NAME	SPEC.	QUANTITY	CODE NO.
1	BILLBOARD SIDE COVER ACRYL-L	ACRYL-8.0t	1	MPLX0ACR018
2	BILLBOARD SIDE COVER ACRYL-R	ACRYL-8.0t	1	MPLX0ACR002
3	BILLBOARD TITLE FRONT ACRYL	ACRYL-3.0t	1	MPLX0ACR005
4	PIU BILLBOARD PRIME2	-0.5t	1	MPLX0ACR004
5	BILLBOARD TITLE BACK ACRYL	ACRYL-5.0t		MPLX0ACR003
6	12V_LED BAR PCB ASS'Y	-	2	AZZZ0PCB124
7	WEB CAM	-	1	MZZZ0000604

7-16. BASE LIGHT DECO PART

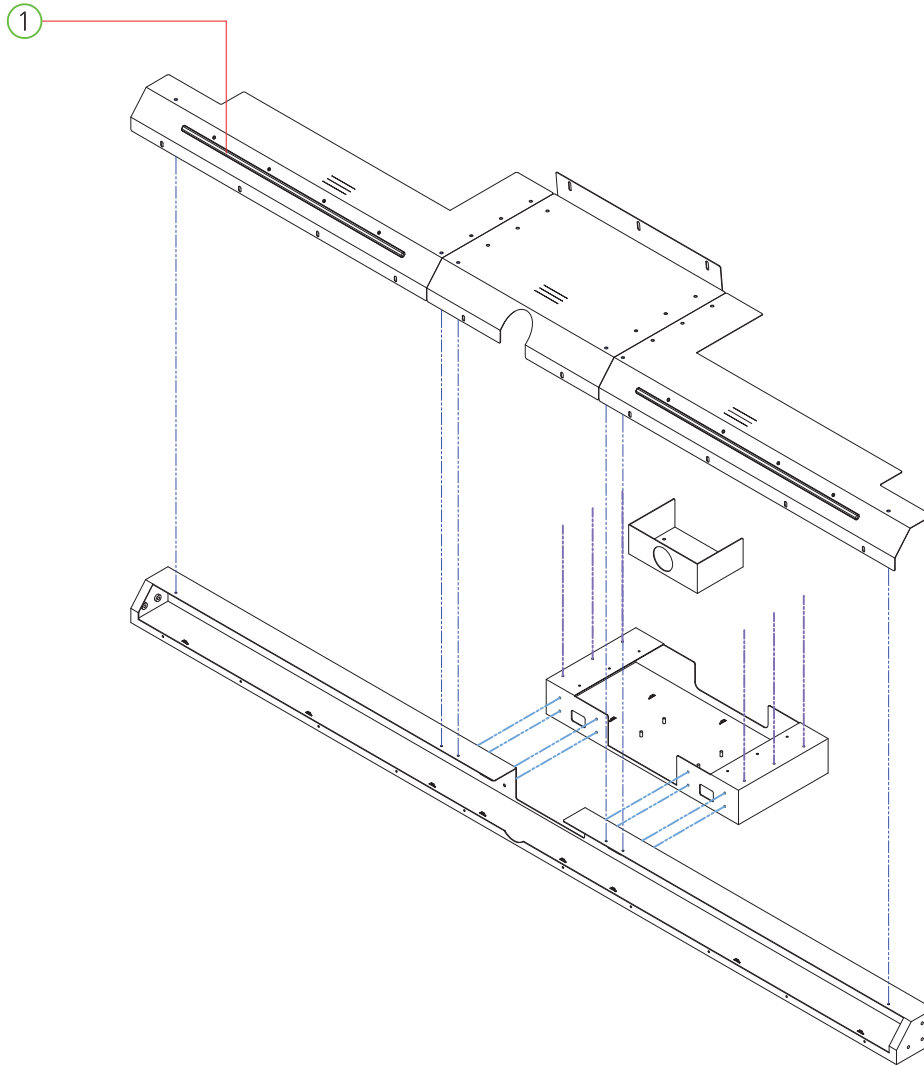

NO.	PART NAME	SPEC.	QUANTITY	CODE NO.
1	BASE LIGHT DECO ACRYL	ACRYL-8.0t	2	MPLX0ACR001

7-17. [OPTION] POP PART

L

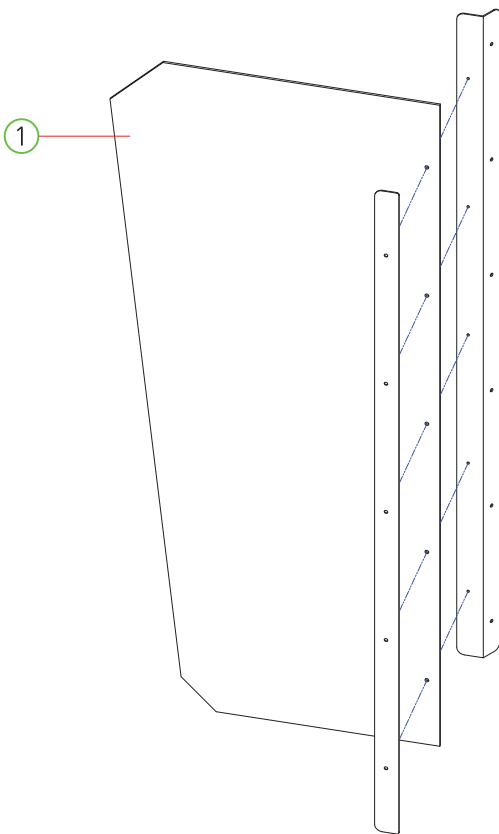

R

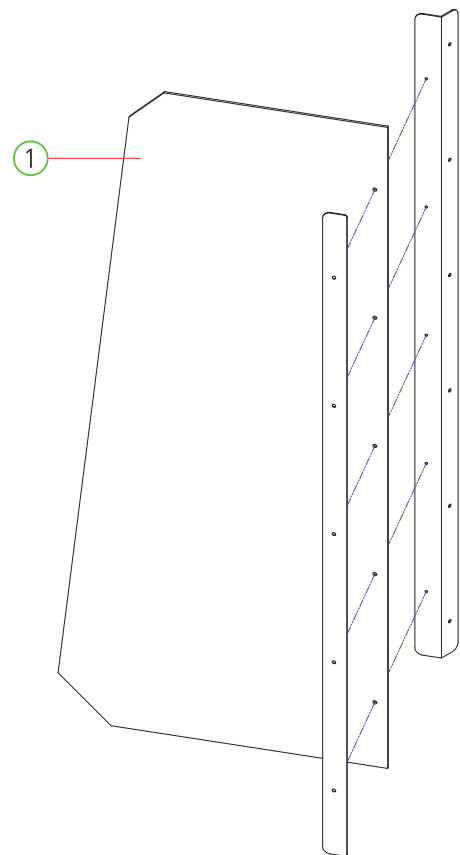

NO.	PART NAME	SPEC.	QUANTITY	CODE NO.
1	SIDE POP-L, R	-	2	MPLX0ACR021, 016

MARK	DATE	REVISION	DRAWN BY	CHECKED BY	APPROVED BY

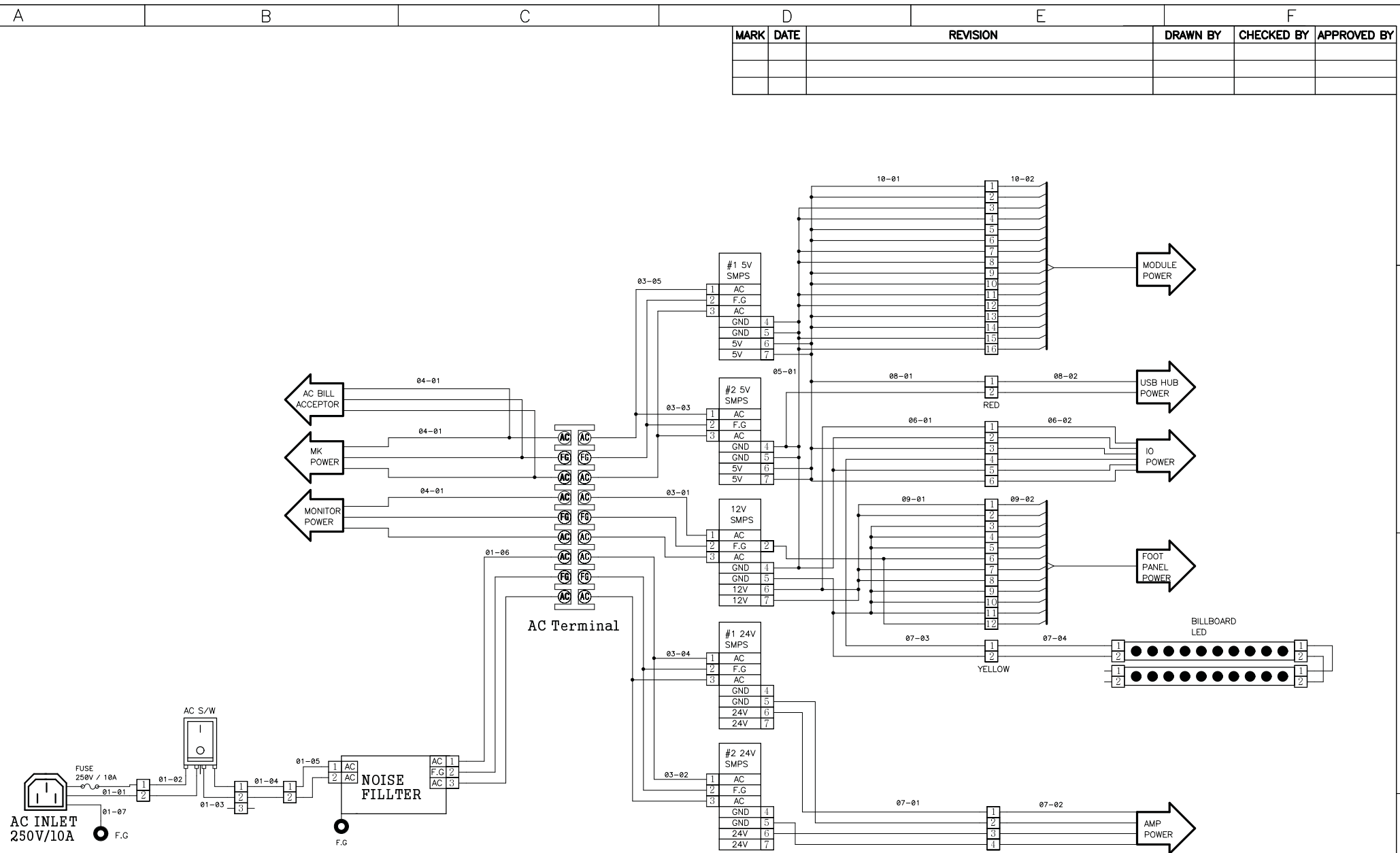

DRAWN BY	EXAMINATION	APPROVED BY	DATE	2017.01.11
CHO.Y.Y			ITEM	PUMP IT UP LX
			SCH.NAME	POWER BOX
			SCH.NO.	1/6
			CODE.NO.	

MARK	DATE	REVISION	DRAWN BY	CHECKED BY	APPROVED BY

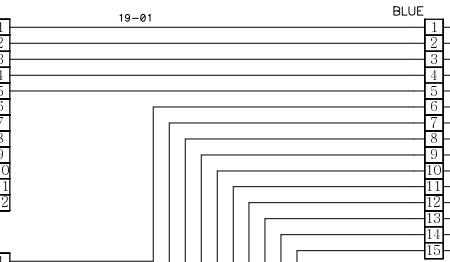
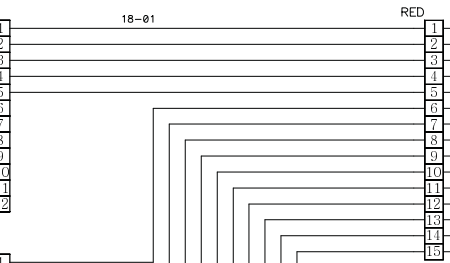
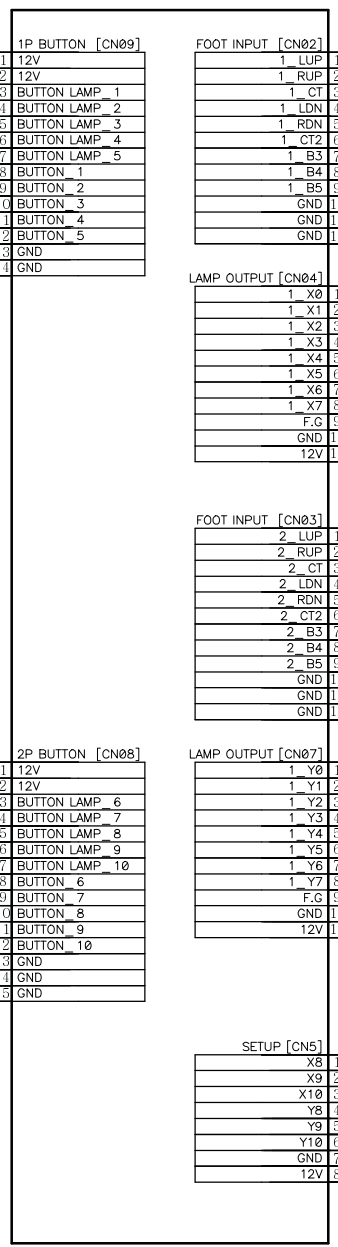
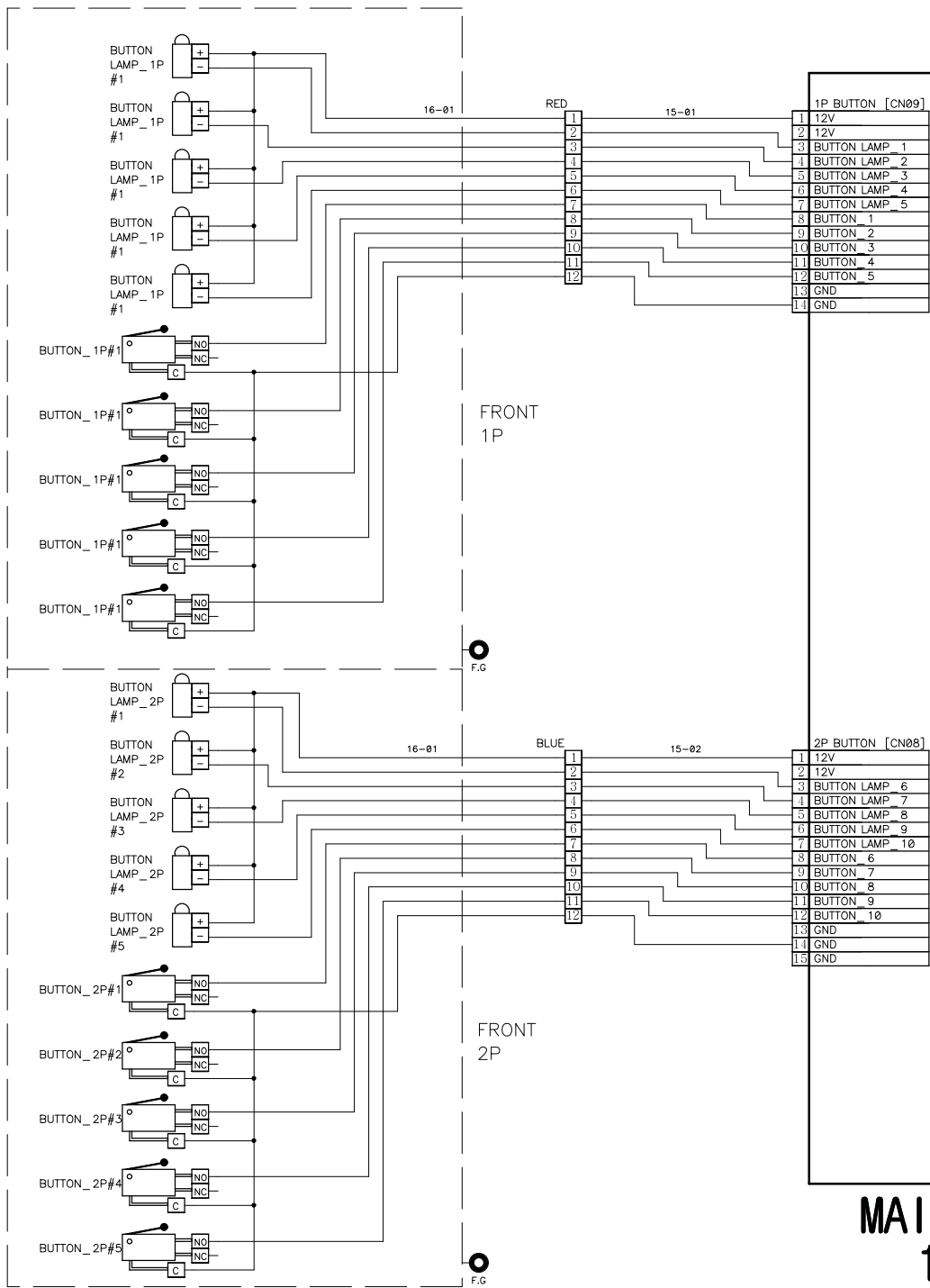

MAIN I/O
1/2

DRAWN BY	EXAMINATION	APPROVED BY	DATE
CHO.Y.Y			
			ITEM PUMP IT UP LX
			SCH.NAME IO 2-1
			SCH.NO. 2/6
			CODE.NO.

MARK	DATE	REVISION	DRAWN BY	CHECKED BY	APPROVED BY

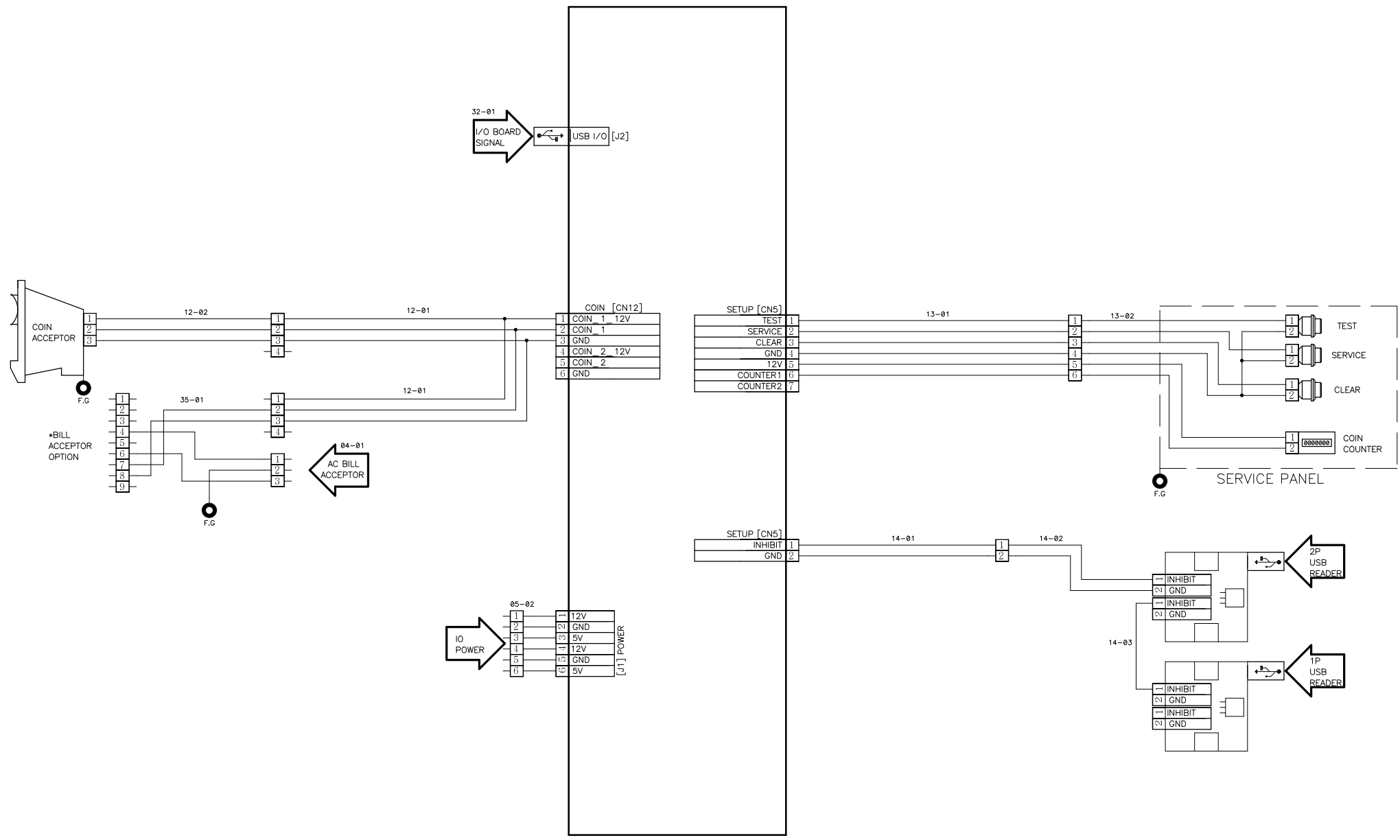

MAIN I/O
2/2

DRAWN BY	EXAMINATION	APPROVED BY	DATE
CHO.Y.Y			
			ITEM PUMP IT UP LX
			SCH.NAME IO 2-2
			SCH.NO. 3/6
			CODE.NO.

MARK	DATE	REVISION	DRAWN BY	CHECKED BY	APPROVED BY

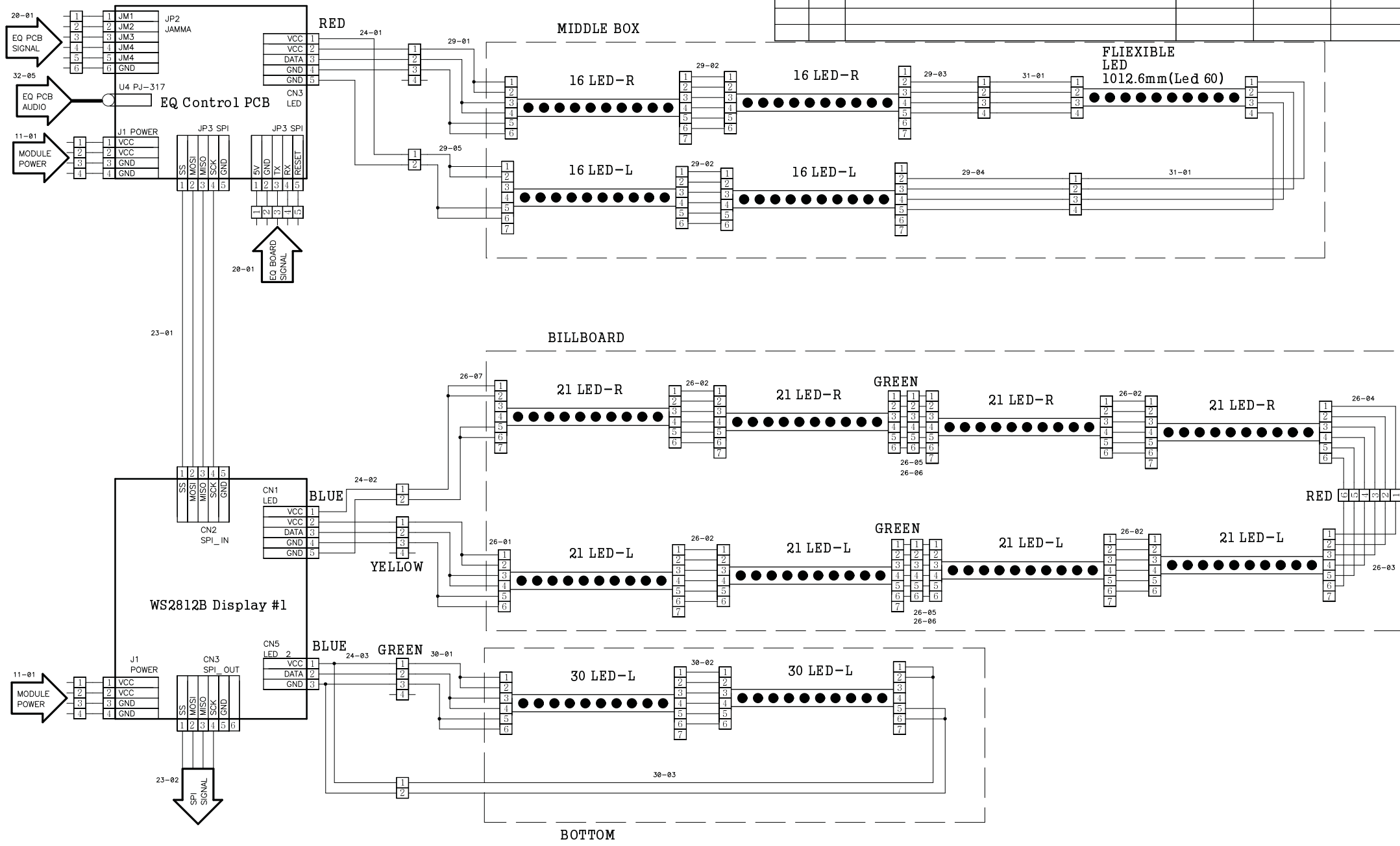

DRAWN BY	EXAMINATION	APPROVED BY	DATE
CHO.Y.Y			

ITEM	DATE
PUMP IT UP LX	
SCH.NAME	LED MODULE 2-1
SCH.NO.	4/6
CODE.NO.	

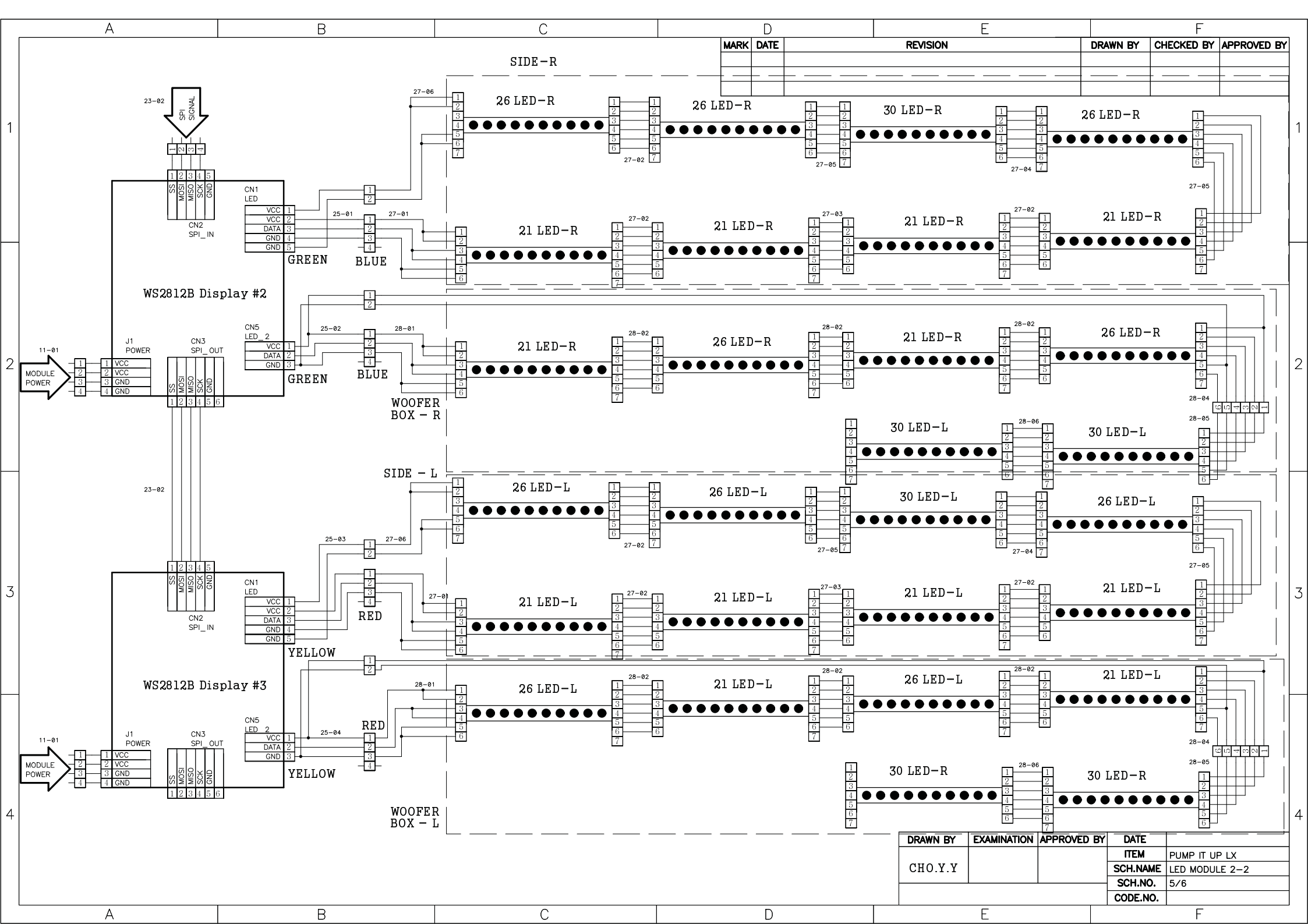

DRAWN BY	EXAMINATION	APPROVED BY	DATE
CHO.Y.Y			
			ITEM PUMP IT UP LX
			SCH.NAME LED MODULE 2-2
			SCH.NO. 5/6
			CODE.NO.

MARK	DATE	REVISION	DRAWN BY	CHECKED BY	APPROVED BY

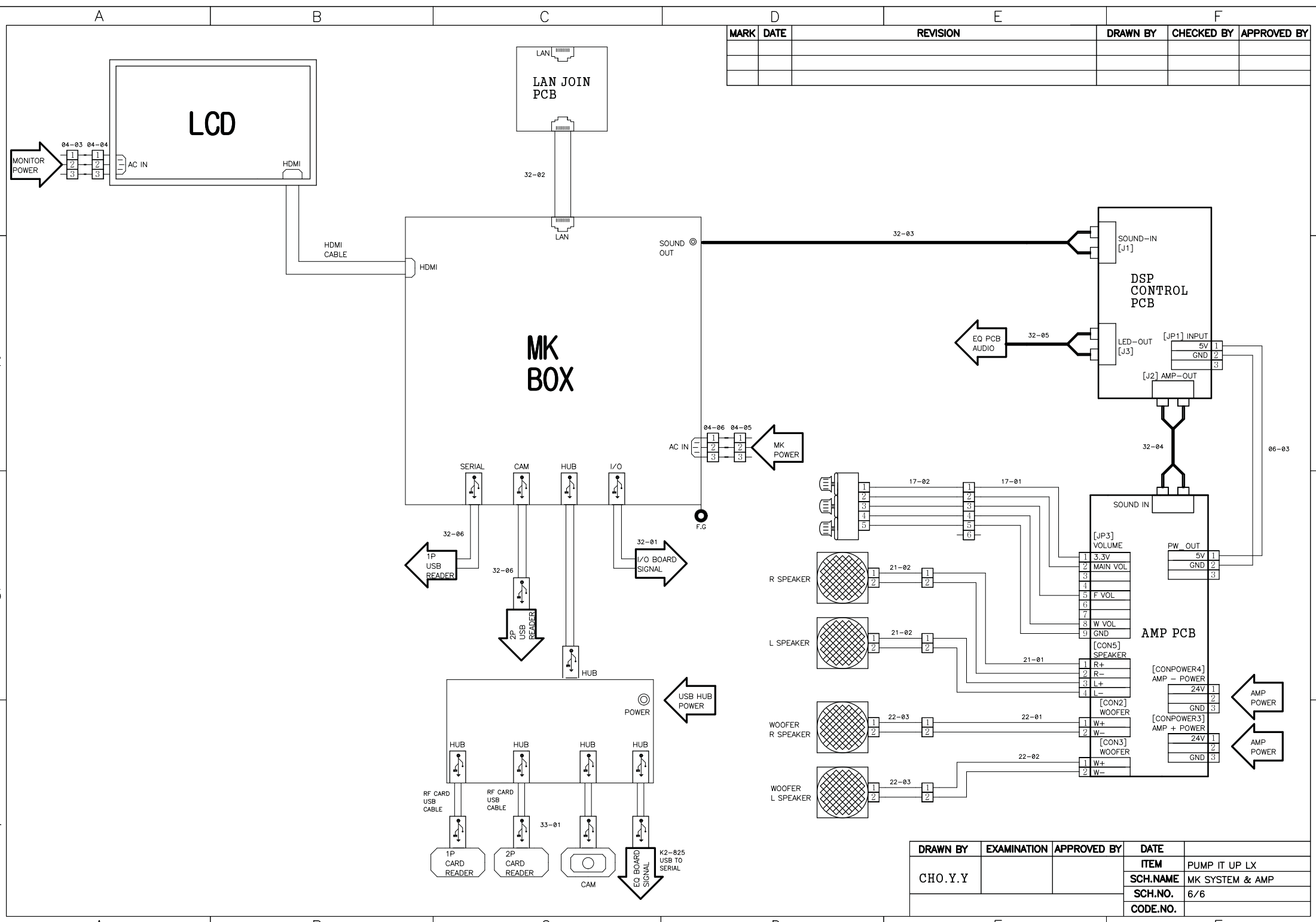

DRAWN BY	EXAMINATION	APPROVED BY	DATE	ITEM
CHO.Y.Y				PUMP IT UP LX
				SCH.NO. MK SYSTEM & AMP
				SCH.NO. 6/6
				CODE.NO.



ANDAMIRO WARRANTY POLICY



Andamiro warrants to the original purchaser that all of its products will be free from defects in material and workmanship.

Andamiro warrants the parts from date of shipment as follows.

- **One Year Limited Warranty : Electronic Boards & Monitor**
- **6 Month Limited Warranty : Moving Parts**

For any key components within the warranty period, Andamiro will repair or replace defective components free of charge.

When placing a warranty request, the customer is requested to furnish the following information:

1. Name of the game.
2. Serial Number of the game.
3. A Detailed Description of the defect/s experienced.

This warranty does not apply to the defects caused due to misuse or abuse of the product.

Any alterations made to game or game parts will void this warranty.

For warranty details on our product range please visit our website, www.andamiro.com.

ANDAMIRO CO., LTD.
www.andamiro.com



Please complete the following request form to place a warranty request and send it to ANDAMIRO Korea either by fax (Fax No: +82-31-908-7548) or by e-mail. The e-mail address of the person in charge of each region is shown in our web-site, www.andamiro.com

For the on-line request, please visit our web-site, www.andamiro.com and click "Customer Service" and then click "Contact Us" in which you shall find the e-mail address of the person in charge of each region.

1. Company Name : _____

2. Mailing Address : _____

3. E-Mail Address : _____

4. Phone No : _____

5. Name of the person in charge : _____

6. Description of the product defects

6-1) Name of the Game : _____

6-2) Serial No : _____

6-3) Date of Purchase : _____

6-4) Detailed description of the product defects.

Remarks: If possible, please provide us with related photos and videos which will be greatly appreciated to verify the cause of the problem.



ANDAMIRO CO., LTD.
TEL : 82-31-909-2123~4,2051

[ADDRESS OFFICE] 6006 M-City Tower, 195, Baengmaro, Ilsandong-gu, Goyang-si,
Gyeonggi-do, 410-834 Korea
[FACTORY] 72 Nochemgil, Ilsan-donggu Goyang-si, Gyeonggi-do, 410-834 korea

USA BRANCH
ANDAMIRO USA CORP.
17230 S. Main Street
TEL : 1-310-767-5800

[ADDRESS] Gardena, California 90248 U.S.A.

Homepage <http://www.andamiro.com/>